

Voltage and Frequency Relay UFR1001E

Grid- and Plant Protection VDE-AR-N 4105, G98 + G99, DIN V VDE 0126-1-1, VFR2013/2014, NRS 0972-1:2017 Ed 2, Synergrid C10/C11, EN50438:2013, RD1699:2011/RD413:2014 and more

NEW: VDE-AR-N 4120:2018-11, VDE-AR-N 4105:2018-11, VDE-AR-N 4110:2018-11

UFR1001E



Part numbers:

UFR1001E S222296

ER6 T224386



The grid- and plant protection device UFR1001E monitors voltage and frequency in plants for own generation of electricity. It complies with the requirements of VDE-AR-N 4105:2018-11, VDE-AR-N 4110:2018-11, G98, G99, ÖVE/ÖNORM E 8001-4-712:2009 and other standards for generators connected to the public grid.

The UFR1001E is a dual-channel device and thus one-fault-proof. The function of the output-relays and of the connected switches can be monitored with feed-back contacts. When a connected switch does not switch

off, the UFR does not switch on again. When a switch does not switch on it makes 2 restarts and thus improves availability of monitored plant.

The limits are pre-set according to VDE-AR-N 4105:2018-11, VDE-AR-N 4105:2018-11 and other standards. They can be changed if required and be protected with a code and/or a seal.

With a 2-step test both channels can be tested individually and the triggering time of connected switches is measured. The standby input allows a remote shutoff e.g. with a RCR.

Monitoring of:

- Under- and overvoltage 15...520 V (with voltage transformers up to 1000V)
- Under- and overfrequency 45...65 Hz
- Quality of voltage (10-minutes-average)
- Vector shift 2...65°, *zuschaltbar*
- Measuring phase-neutral or phase-phase
- ROCOF rate of change of frequency df/dt 0,100...5,000 Hz/s
- Zero voltage U_0 (ANSI 59v0)

- One-fault-proof with monitoring of connected switches (defeatable when using the integrated switch of pv and battery inverter acc. to DIN EN 62109 (VDE 0126-4))
- 2 automatic restarts at switch-on error
- Passive anti-islanding protection acc. to ch. 6.5.3 and app. D2
- Switching delay adjustable 0.05 ... 300 s
- Switching back delay adjustable 0 ... 6.000 s
- Alarm counter for 100 alarms (trip value, cause and rel. time stamp)
- Record of added times of alarms
- Input for standby with counter and recording of time
- Test button and simulation with measuring of switching-times
- Sealing. All values can be read-out when sealed
- Easy installation and programming with pre-set programs
- Housing for DIN-rail-mount, 105 mm wide, mounting height 66 mm

Accessory: [Installation frame ER6 for panel mount](#)

Preset values:

- VDE-AR-N 4105:2018-11 (Pr2), VDE-AR-N 4105-2011-08 (Pr1)
- VDE-AR-N 4110:2018-11 (PR11-14) and BDEW (Pr 3-6)
- G98 (G83/2) and G99 (G59/3) for Great Britain
- TOR producers type A, B, C, D for Austria
- Synergrid C10/C11 for Belgium
- NA/EEA-NE7 CH 2020 for Switzerland

Certificates:



Certificate of conformity Grid and Plant protection acc. to VDE-AR-N 4105 2011-08 and 2018-11 "Plants for generation of own energy in low voltage grid"

Certificate for component VDE-AR-N 4110 and 4120

Certificate of conformity Grid and Plant protection acc. to BDEW requirement "Plants for generation of own energy in medium voltage grid"



Certificate of compliance DIN V VDE 0126-1-1



gelistet bei Energex RED STD00233



TOR Erzeuger A,B,C,D



Certificate ÖVE/ÖNORME 8001-4-712:2009-12, Enclosure A



approved Synergrid C10/C11



Certificate de conformité
DIN V VDE 0126-1-1, VFR2013/VFR 2014



Certificate of compliance G59/3:2013, G83/2:2012, G99/1-1+2+3:2018 und G98/1-1+2:2018



Certificate of compliance EN 50438:2013



accepted by Tepco



Netherlands EN50549-1



RD1699:2011 / RD413:2014



Certificate of compliance NRS 097-2-1:2017 2.0 South Africa

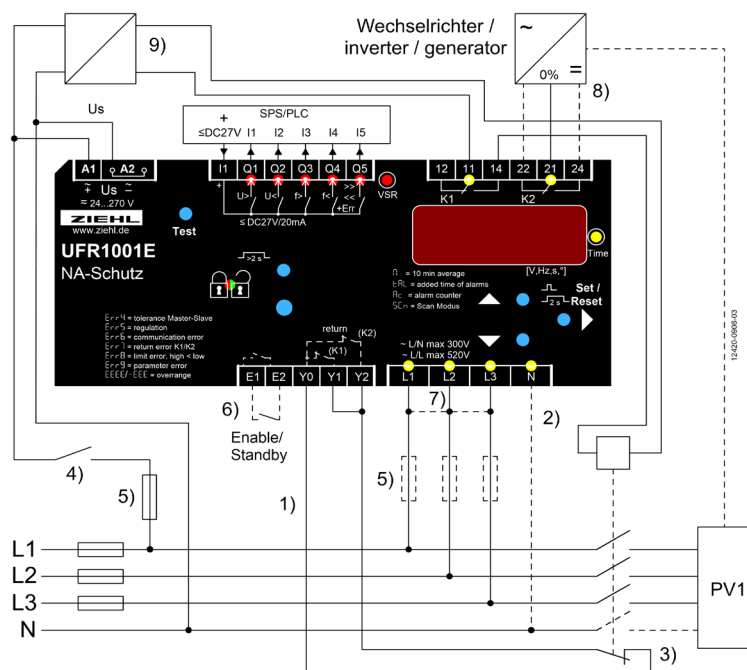

Technical Data UFR1001E

Power supply	Rated supply voltage U_s	AC/DC 24-270 V, 0/45...65 Hz, <5VA DC: 20,4...297 V, AC: 20,4...297 V
Relay output		2 change-over contacts see operating manual
Voltage	Measurement phase-phase Setting range phase-phase Measuring voltage phase-neutral Setting range phase-neutral Measurement method Hysteresis Measurement accuracy Accuracy of display Measurement functions Switching-delay (dAL) Switching-back-delay (doF)	AC 15...530 V (< 5 V display: 0) AC 15...520 V AC 10...310 V (< 5 V display: 0) AC 15...300 V true RMS adjustable 1,0...180 V with neutral: $\pm 0,6\%$ of measured value without neutral: $\pm 0,8\%$ of measured value >100V: -1 digit (resolution 1 V) <100V: -1 digit (resolution 0,1 V) 3-phase with / without neutral adjustable 0,05 (± 15 ms)...300,0 s adjustable 0 (approx. 200 ms)...6.000 s
Frequency	Measurement range Setting range Hysteresis Measurement accuracy Switching delay (dAL) Switching-back-delay (doF)	40...70 Hz 45,00...65,00 Hz 0,05...10,00 Hz $\pm 0,04$ Hz ± 1 digit adjustable 0,05 (± 15 ms)...300,0 s adjustable 0 (>200 ms)...6.000 s
Vector-Shift	Measurement range Setting range Switching-delay (dAL) Switching-back-delay (doF) Delay at U_s on	0...90,0° 2,0...65,0° < 50 ms adjustable 3...240 s adjustable 2...20 s
ROCOF (df/dt)	Setting range	0,100...5,000 Hz/s, 4...50 cycles
Digital outputs insulated	Voltage I1 Current Q1...Q5	DC 4,5...27 V max. 20 mA / output
Input Feed-back-contacts	Voltage Y0...Y1/2 Switching time connected switches	DC 15...35 V adjustable 0,5...99,0 s
Test Conditions		EN 60255 Rated impulse voltage 4000 V Overvoltage category III Pollution degree 2 Rated Insulation voltage U_i 300 V Operating time 100 % Operating temperature -20 °C...+55 °C Storage temperature -25 °C...+70 °C Climatic conditions (IEC/EN 60721-3-3) 3K5 (except condensation and formation of ice)
	EMC - immunity EMC - emission	EN 61 000-6-2 EN 61 000-6-3
Housing	Design / Installation Frame Dimensions (h x w x d) Protection housing Protection terminals Attachment Weight	V6 / Front mounting kit type ER6, 6 TE 90 x 105 x 69 mm, mounting height 66 mm IP30 IP20 DIN-rail 35 mm according to EN 60 715 or screws M4 ca. 250 g