

Kurzbezeichnung: UFR1001E	Bezeichnung: Example connection plans UFR1001E	ZIEHL	
bearbeitet: 2021-11-29/Ba	Table of contents	Maßstab: -	Ers. für: 12420-0911-12
		EA-Nr.: 15390	Zeichnungsnummer: 12420-0911-13
			page: 1 of 22

Table of contents example connection plans UFR1001E

- Page 2 VDE-AR-N 4105:2018-11, NA/EEA-NE7 – CH 2020 switcher with motor drive and undervoltage release
- Page 3 VDE-AR-N 4105:2018-11, 2NA/EEA-NE7 – CH 2020 4VDC relay and DC power supply alt. with buffer
- Page 4 VDE-AR-N 4105:2018-11, NA/EEA-NE7 – CH 2020 connection plan 1x ABB Tmax T2, T4-T6 4105:2018
- Page 5 VDE-AR-N 4105:2018-11, NA/EEA-NE7 – CH 2020 connection plan SE NSX compact
- Page 6 VDE-AR-N 4105:2018-11, NA/EEA-NE7 – CH 2020 switcher with motor drive and undervoltage release
NA-protection and switcher separated, signals over coupling-relay
- Page 7 VDE-AR-N 4110+4120:2018-11, switcher with motor drive and undervoltage release
- Page 8 VDE-AR-N 4110+4120:2018-11, switcher with motor drive and undervoltage release
NA-protection and switcher separated, signals over coupling-relay
- Page 9 VDE-AR-N 4105:2018-11, NA/EEA-NE7 – CH 2020 using integrated switches
of PV and battery inverters according to DIN EN 62109 (VDE 0126-4)
- Page 10 VDE-AR-N 4105:2018-11, NA/EEA-NE7 – CH 2020 SMA Core1 using integrated switches
over SMA I/O Module MD.IO-40 (required for each inverter)
- Seite 11 VDE-AR-N 4105:2018-11, NA/EEA-NE7 – CH 2020 Fronius using integrated switches
Symo / Eco / Primo, signals over coupling-relay with wide range
- Page 12 VDE-AR-N 4105:2018-11, existing plant 2 switchers + new plant 1 switcher and 2nd switch-off path, 24VDC relay and
DC power supply alt. with buffer
- Page 13 VDE-AR-N 4105:2011, 1x generation plants, 2x switchers
(without FRT, not permitted for new systems)
- Page 14 VDE-AR-N 4105:2018-11, 2x plant 1 switcher each and 2nd switch-off path, 24VDC relay
and DC power supply alt. with buffer, opener feedback contacts in series
- Page 15 VDE-AR-N 4105:2018-11, 2x plant 1 switcher each and 2nd switch-off path, 24VDC relay
DC power supply alt. with buffer, closer feedback contacts parallel
- Page 16 VDE-AR-N 4105:2011, VDE-AR-N 4105:2018-11(Pgen<= 50kW), Generator without FRT
- Page 17 VDE-AR-N 4105:2018-11, Huawei using integrated switches, inverter series M2 and M3
- Page 18 VDE-AR-N 4110:2018-11, TESVOLT TS-I HV 80 switcher with motor drive and undervoltage release
- Page 19 VDE-AR-N 4105:2018-11, NA/EEA-NE7 – CH 2020, 2x 24VDC relay in series and DC power supply alt. with buffer
- Page 20 VDE-AR-N 4105:2018-11, Huawei using integrated switches inverter 60KTL-M0 and 100KTL-M1 with SmartLogger SL3000
- Page 21 VDE-AR-N 4105:2018-11, existing plant 2 switchers + new plant 2 switchers, 24VDC relay and
DC power supply alt. with buffer
- Page 22 VDE-AR-N 4105:2018-11, Sungrow SG 33/40/50CX using integrated switches

Questions to the circuit diagrams?
 Contact us:
 +49 791 5040
 sales@ziehl.de



[UFR1001E operating videos](#)

Recommendations for the FRT component power supply / buffering,
see separate document:

["FRT component recommendation"](#)

**VDE-AR-N 4105:2018-11
NA/EEA-NE7 – CH 2020**

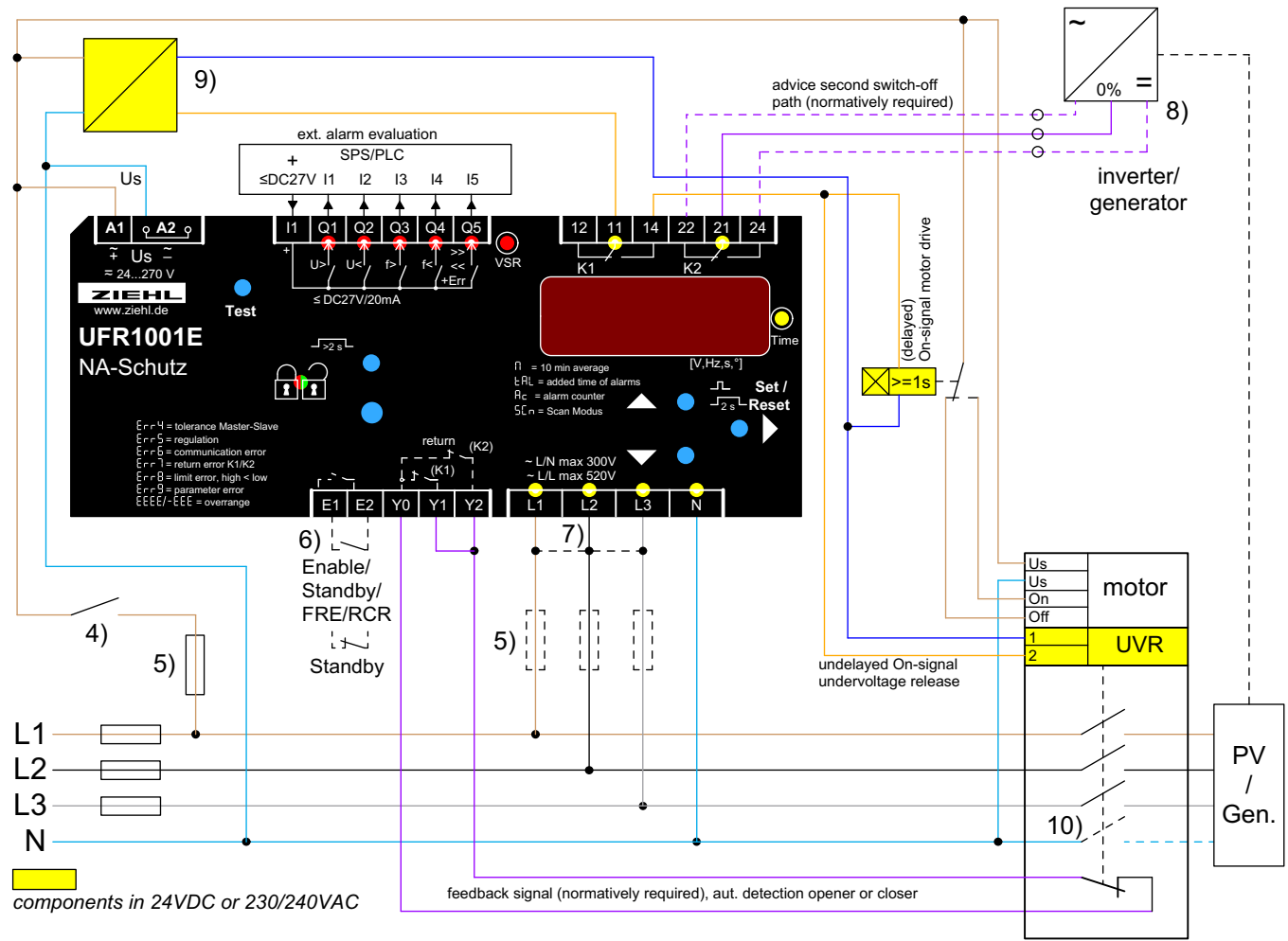

- 4) Switch off of plant without recording an alarm
- 5) Fuses only when line protection necessary, e.g. 16 A
- 6) contact closed and $u_{5r} / 5\epsilon b5$. (default setting since Fnr 0-17) or $u_{5r} / 5\epsilon b4$. (default setting to Fnr 0-16) = Standby, K1+2 switched off (e.g. by ripple control receiver or clock,...)
contact open and $u_{5r} / 5\epsilon b6$. (since Fnr 0-17)= Standby, K1+2 switched off (e.g. by ripple control receiver or clock,...)
- 7) 1 phase Application connect L1-L2-L3, 2 phase Application L1 / L2+L3 (only Pr 5, 7, 10, 13, 20)
- 8) Single-fault safety: shutdown of the self generation plant e.g. by ripple control input 0% with K2. Use coupling relays for contact multiplication if safe isolation is required. (control voltage 24-230VAC or fed over power supply / buffer)
This second switch-off path must be tested separately during commissioning. ($\epsilon 5\epsilon 2$)
- 9) Power supply / buffering. Switches have to withstand undervoltage / voltage breakdown for min. 3 s / 0,3 s (FRT)
The power supplies listed in the separate document "FRT Komponenteneempfehlung", in connection with 24VDC contactors / undervoltage release, ensure that the switch-off delay time (3s) is fulfilled in the event of undervoltage. Bridging time UFR1001E at dropping U_s 230 V to 0 V: 400 ms
- 10) TT-system: switch all line conductors and N, TN-system: only switch line conductor



VDE-AR-N 4105:2018-11
NA/EEA-NE7 – CH 2020

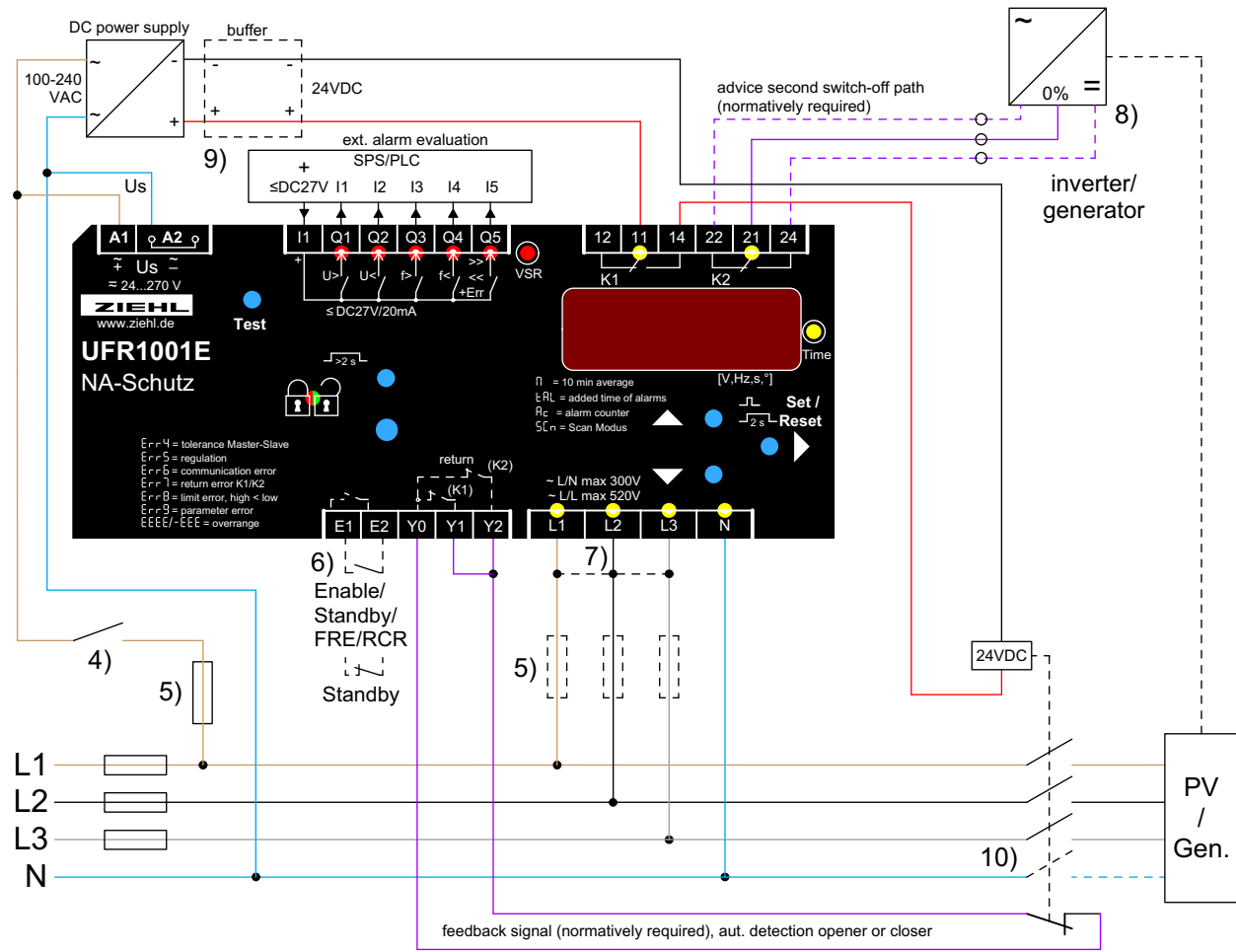

- 4) Switch off of plant without recording an alarm
- 5) Fuses only when line protection necessary, e.g. 16 A
- 6) contact closed and $U_{5r} / 5\epsilon b5$. (default setting since Fnr 0-17) or $U_{5r} / 5\epsilon b4$. (default setting to Fnr 0-16) = Standby, K1+2 switched off (e.g. by ripple control receiver or clock,...)
contact open and $U_{5r} / 5\epsilon b6$. (since Fnr 0-17)= Standby, K1+2 switched off (e.g. by ripple control receiver or clock,...)
- 7) 1 phase Application connect L1-L2-L3, 2 phase Application L1 / L2+L3 (only Pr 5, 7, 10, 13, 20)
- 8) Single-fault safety: shutdown of the self generation plant e.g. by ripple control input 0% with K2. Use coupling relays for contact multiplication of if safe isolation is required. (control voltage 24-230VAC or feeded over power supply / buffer)
This second switch-off path must be tested separately during commissioning. ($\epsilon 5\epsilon 2$)
- 9) Power supply / buffering. Switches have to withstand undervoltage / voltage breakdown for min. 3 s / 0,3 s (FRT)
The power supplies listed in the separate document "FRT Komponenteneempfehlung", in connection with 24VDC contactors / undervoltage release, ensure that the switch-off delay time (3s) is fulfilled in the event of undervoltage. Bridging time UFR1001E at dropping U_s 230 V to 0 V: 400 ms
- 10) TT-system: switch all line conductors and N, TN-system: only switch line conductor



VDE-AR-N 4105:2018-11
NA/EEA-NE7 – CH 2020

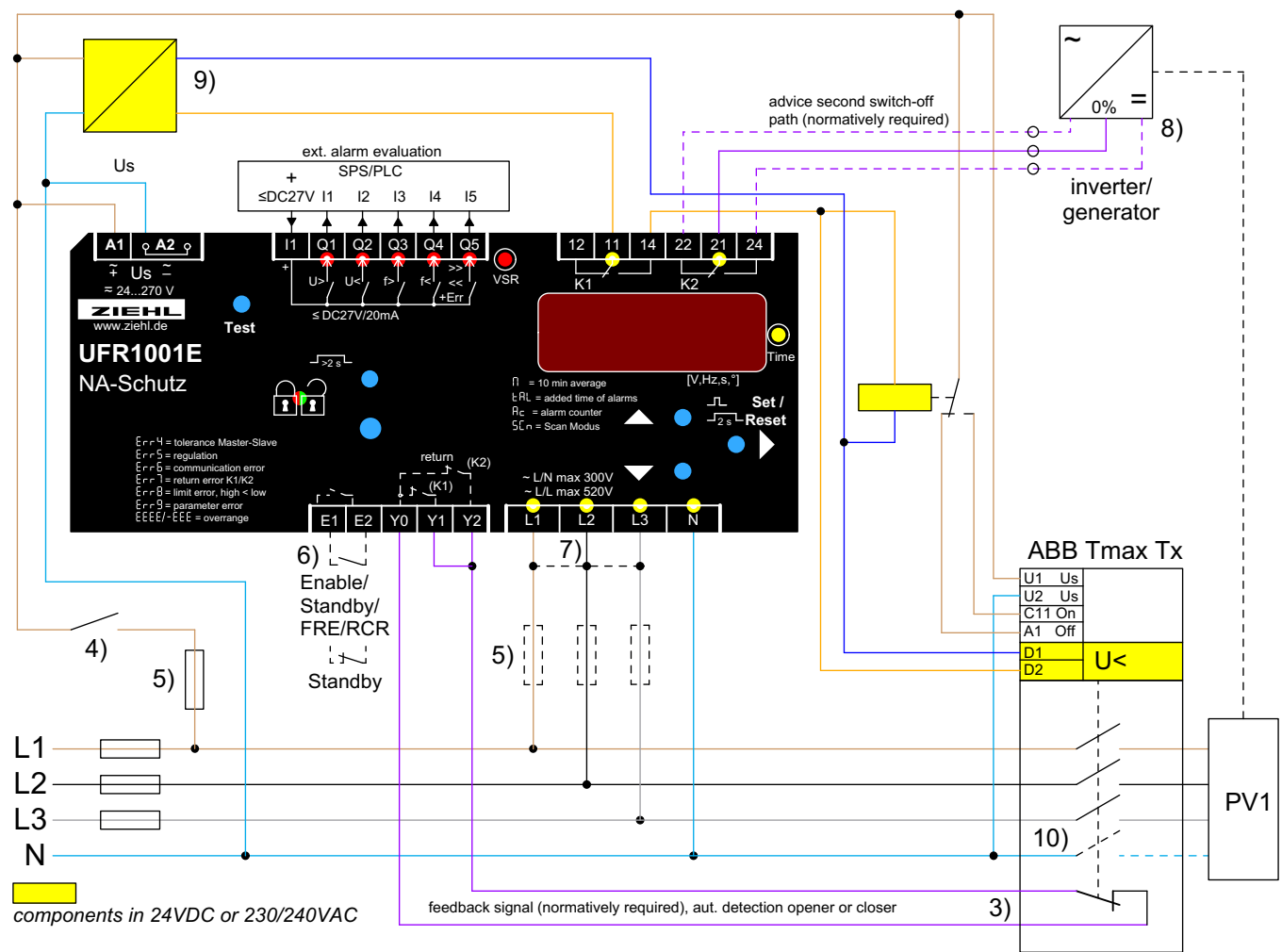

- 3) NC- or NO-contacts can be connected, self-learning when switching on
- 4) Switch off of plant without recording an alarm
- 5) Fuses only when line protection necessary, e.g. 16 A
- 6) contact closed and $u_{5r} / 5t_{b5}$. (default setting since Fnr 0-17) or $u_{5r} / 5t_{b9}$. (default setting to Fnr 0-16) = Standby, K1+2 switched off (e.g. by ripple control receiver or clock,...)
contact open and $u_{5r} / 5t_{b0}$. (since Fnr 0-17)= Standby, K1+2 switched off (e.g. by ripple control receiver or clock,...)
- 7) 1 phase Application connect L1-L2-L3, 2 phase Application L1 / L2+L3 (only Pr 5, 7, 10, 13, 20)
- 8) Single-fault safety: shutdown of the self generation plant e.g. by ripple control input 0% with K2. Use coupling relays for contact multiplication of if safe isolation is required. (control voltage 24-230VAC or feeded over power supply / buffer)
This second switch-off path must be tested separately during commissioning. (t_{5t2})
- 9) Power supply / buffering. Switches have to withstand undervoltage / voltage breakdown for min. 3 s / 0,3 s (FRT)
The power supplies listed in the separate document "FRT Komponenteneempfehlung", in connection with 24VDC contactors / undervoltage release, ensure that the switch-off delay time (3s) is fulfilled in the event of undervoltage. Bridging time UFR1001E at dropping U_s 230 V to 0 V: 400 ms
- 10) TT-system: switch all line conductors and N, TN-system: only switch line conductor

VDE-AR-N 4105:2018-11
NA/EEA-NE7 – CH 2020

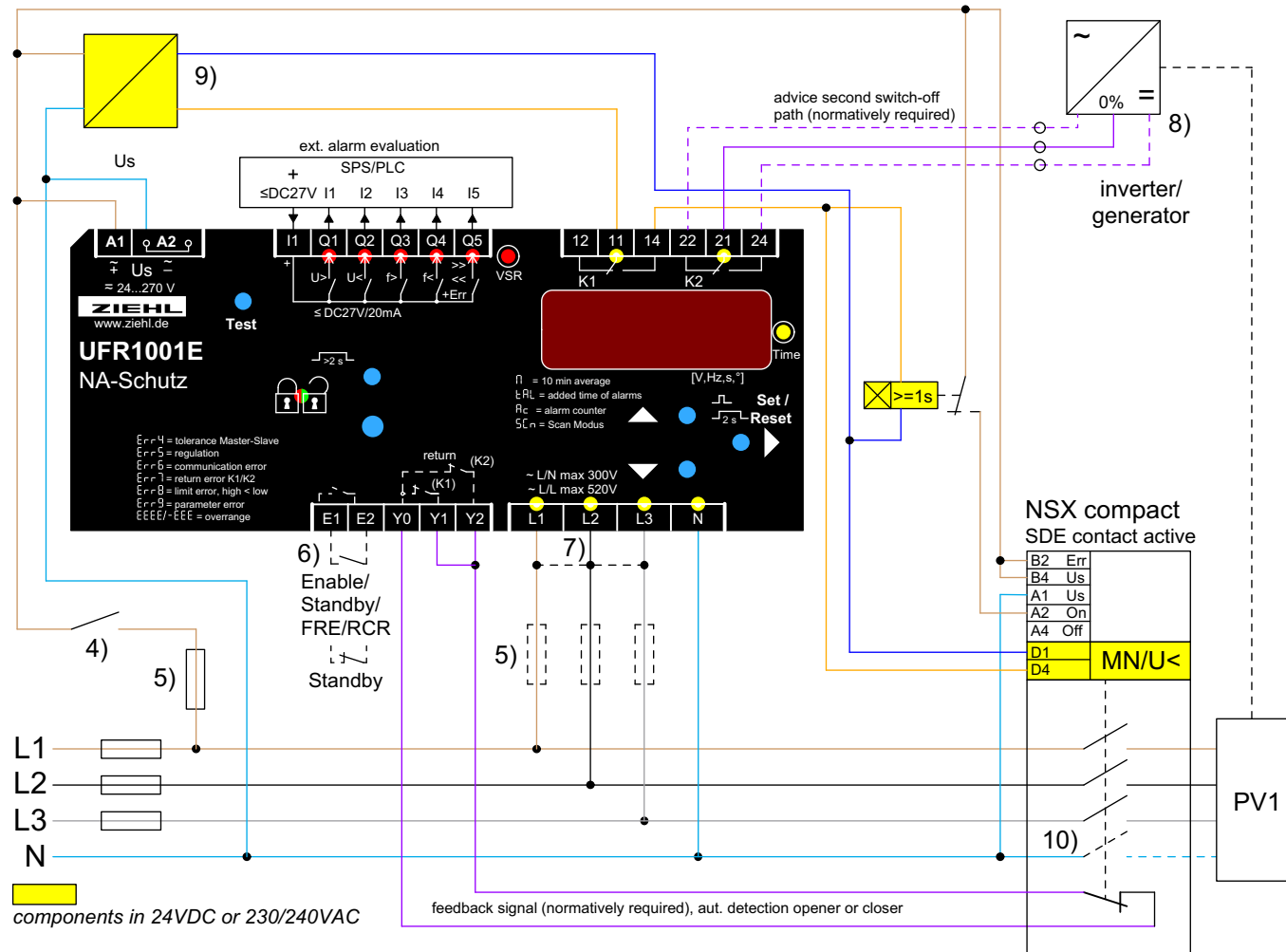

- components in 24VDC or 230/240VAC
- 4) Switch off of plant without recording an alarm
 - 5) Fuses only when line protection necessary, e.g. 16 A
 - 6) contact closed and u_{5r} / 5t₅. (default setting since Fnr 0-17) or u_{5r} / 5t₅. (default setting to Fnr 0-16) = Standby, K1+2 switched off (e.g. by ripple control receiver or clock,...)
contact open and u_{5r} / 5t₅. (since Fnr 0-17)= Standby, K1+2 switched off (e.g. by ripple control receiver or clock,...)
 - 7) 1 phase Application connect L1-L2-L3, 2 phase Application L1 / L2+L3 (only Pr 5, 7, 10, 13, 20)
 - 8) Single-fault safety: shutdown of the self generation plant e.g. by ripple control input 0% with K2. Use coupling relays for contact multiplication of if safe isolation is required. (control voltage 24-230VAC or feeded over power supply / buffer)
This second switch-off path must be tested separately during commissioning. (t_{5t2})
 - 9) Power supply / buffering. Switches have to withstand undervoltage / voltage breakdown for min. 3 s / 0,3 s (FRT)
The power supplies listed in the separate document "FRT Komponenteneempfehlung", in connection with 24VDC contactors / undervoltage release, ensure that the switch-off delay time (3s) is fulfilled in the event of undervoltage. Bridging time UFR1001E at dropping U_s 230 V to 0 V: 400 ms
 - 10) TT-system: switch all line conductors and N, TN-system: only switch line conductor

VDE-AR-N 4105:2018-11 NA/EEA-NE7 – CH 2020

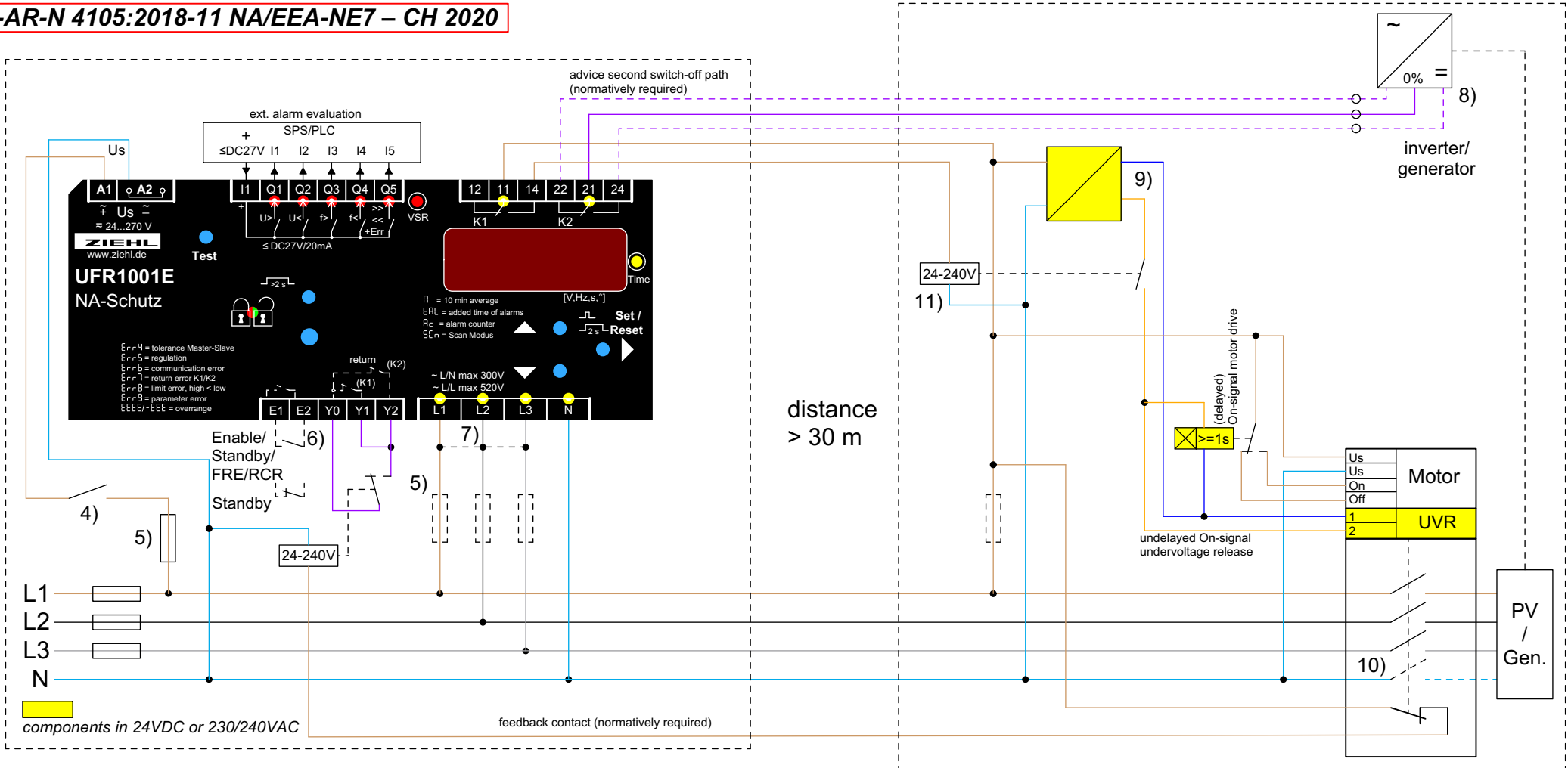

- 4) Switch off of plant without recording an alarm
- 5) Fuses only when line protection necessary, e.g. 16 A
- 6) contact closed and $u_{Sr} / 5\epsilon b5$. (default setting since Fnr 0-17) or $u_{Sr} / 5\epsilon b4$. (default setting to Fnr 0-16) = Standby, K1+2 switched off (e.g. by ripple control receiver or clock,...) contact open and $u_{Sr} / 5\epsilon b6$. (since Fnr 0-17)= Standby, K1+2 switched off (e.g. by ripple control receiver or clock,...)
- 7) 1 phase Application connect L1-L2-L3, 2 phase Application L1 / L2+L3 (only Pr 5, 7, 10, 13, 20)
- 8) **Single-fault safety:** shutdown of the self generation plant e.g. by ripple control input 0% with K2. Use coupling relays ford contact multiplication of if safe isolation is required. (control voltage 24-230VAC or feeded over power supply / buffer) This second switch-off path must be tested separately during commissioning. ($\epsilon 5\epsilon 2$)
- 9) Power supply / buffering. Switches have to withstand undervoltage / voltage breakdown for min. 3 s / 0,3 s (FRT) The power supplies listed in the separate document "FRT Komponenteneempfehlung", in connection with 24VDC contactors / undervoltage release, ensure that the switch-off delay time (3s) is fulfilled in the event of undervoltage. Bridging time UFR1001E at dropping U_s 230 V to 0 V: 400 ms
- 10) TT-system: switch all line conductors and N, TN-system: only switch line conductor
- 11) Coupling relay extends switch-off time (total switch-off time must be ≤ 100 ms)

This information is supplied without liability.

VDE-AR-N 4110+4120:2018-11 (medium voltage)

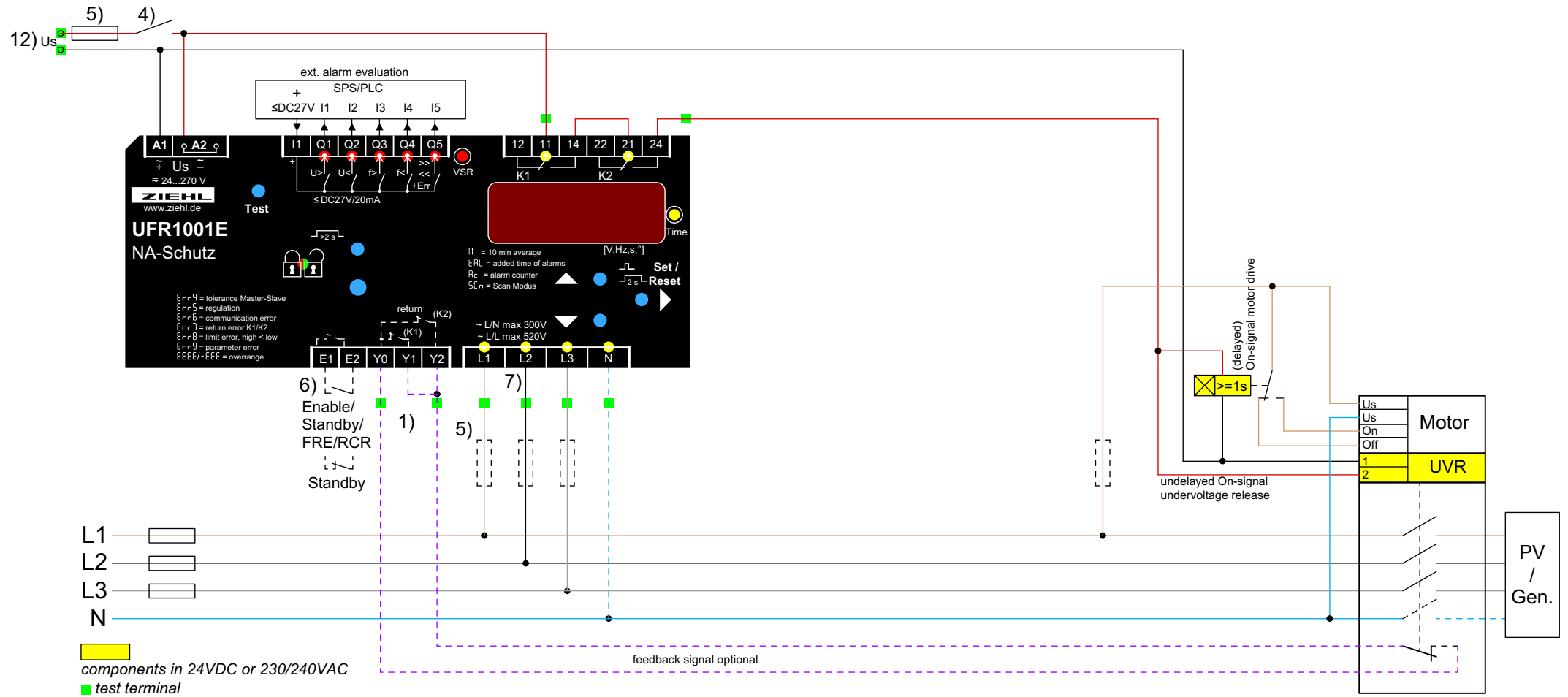

- 1) Feedback contacts not connected: set $t_{rEL} = OFF$ to deactivate feedback-contacts [Video](#)
- 4) Switch off of plant without recording an alarm
- 5) Fuses only when line protection necessary, e.g. 16 A
- 6) contact closed and $u_{Sr} / 5t_{b5}$. (default setting since Fnr 0-17) or $u_{Sr} / 5t_{b4}$. (default setting to Fnr 0-16) = Standby, K1+2 switched off (e.g. by ripple control receiver or clock,...)
contact open and $u_{Sr} / 5t_{b0}$. (since Fnr 0-17)= Standby, K1+2 switched off (e.g. by ripple control receiver or clock,...)
- 12) (existing) control voltage that ensures the protective functions for at min. 5s, e.g. by using a DC power supply unit with wide-range input and buffering

VDE-AR-N 4110+4120:2018-11 (medium voltage)

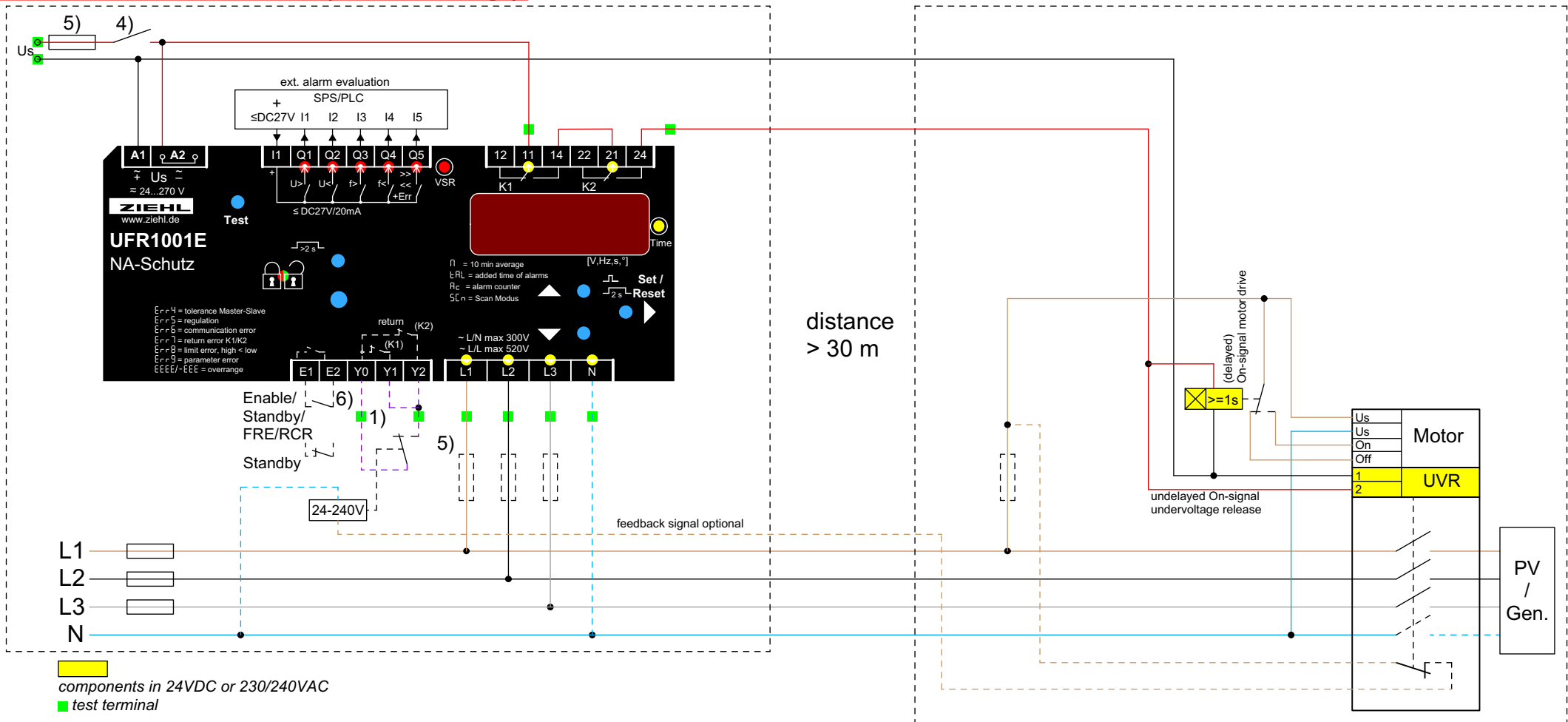

- 1) Feedback contacts not connected: set ErEL = OFF to deactivate feedback-contacts [Video](#)
- 4) Switch off of plant without recording an alarm
- 5) Fuses only when line protection necessary, e.g. 16 A
- 6) contact closed and Usr. / 5Eb5. (default setting since Fnr 0-17) or Usr. / 5Eb9. (default setting to Fnr 0-16) = Standby, K1+2 switched off (e.g. by ripple control receiver or clock,...)
 contact open and Usr. / 5Eba. (since Fnr 0-17)= Standby, K1+2 switched off (e.g. by ripple control receiver or clock,...)

VDE-AR-N 4105:2018-11
NA/EEA-NE7 – CH 2020

short distance (note the max. cable length)

long distance
with coupling relay

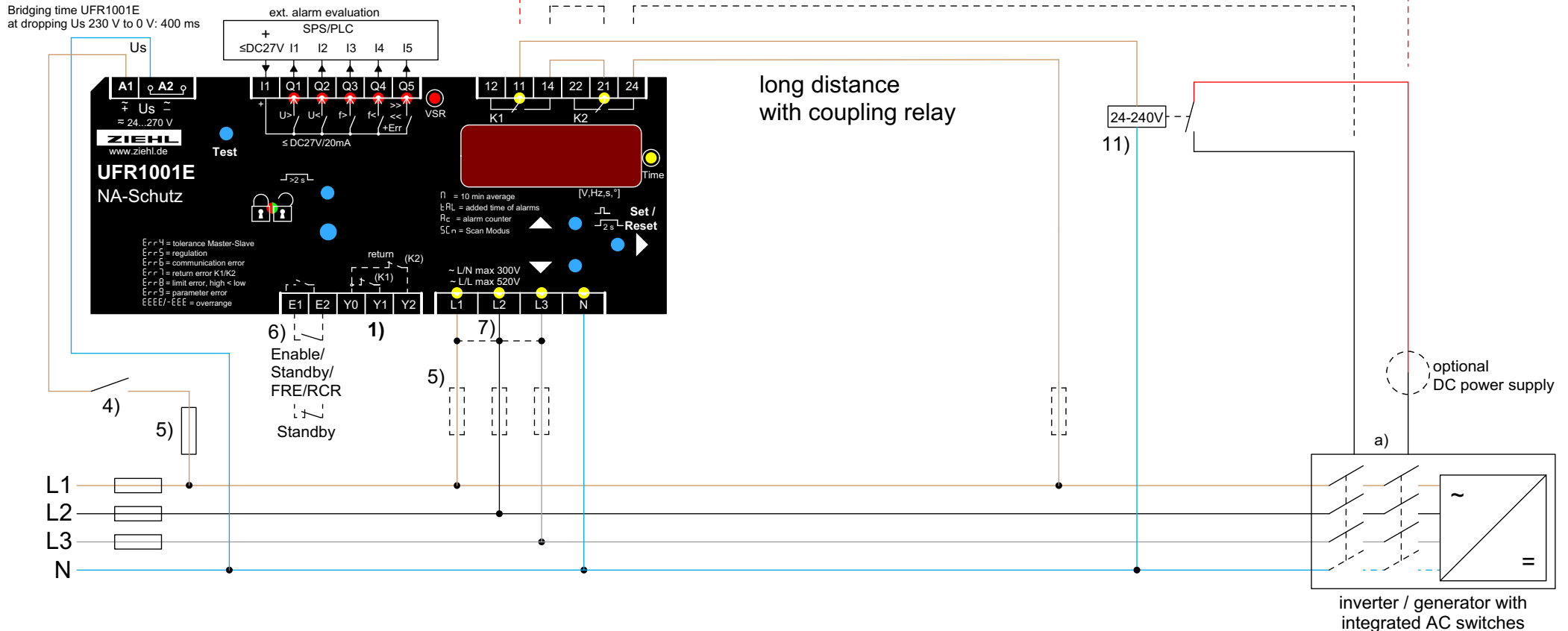

a)	Manufacturer	input module	connectors	max. cable length	ext. power supply
	SMA	MD.IO-40	A1 + A4	200 m	nein
	Solar Edge	Wechselrichter	5V + L1	-	nein

- 1) Feedback contacts not connected: set $t_{rEL} = \text{off}$ to deactivate feedback-contacts [Video](#)
- 4) Switch off of plant without recording an alarm
- 5) Fuses only when line protection necessary, e.g. 16 A
- 6) contact closed and $u_{5r} / 5t_{b5}$. (default setting since Fnr 0-17) or $u_{5r} / 5t_{b5}$. (default setting to Fnr 0-16) = Standby, K1+2 switched off (e.g. by ripple control receiver or clock,...) contact open and $u_{5r} / 5t_{b0}$. (since Fnr 0-17)= Standby, K1+2 switched off (e.g. by ripple control receiver or clock,...)
- 7) 1 phase Application connect L1-L2-L3, 2 phase Application L1 / L2+L3 (only Pr 5, 7, 10, 13, 20)
- 11) Coupling relay extends switch-off time (total switch-off time must be $\leq 100\text{ms}$)

VDE-AR-N 4105:2018-11
NA/EEA-NE7 – CH 2020

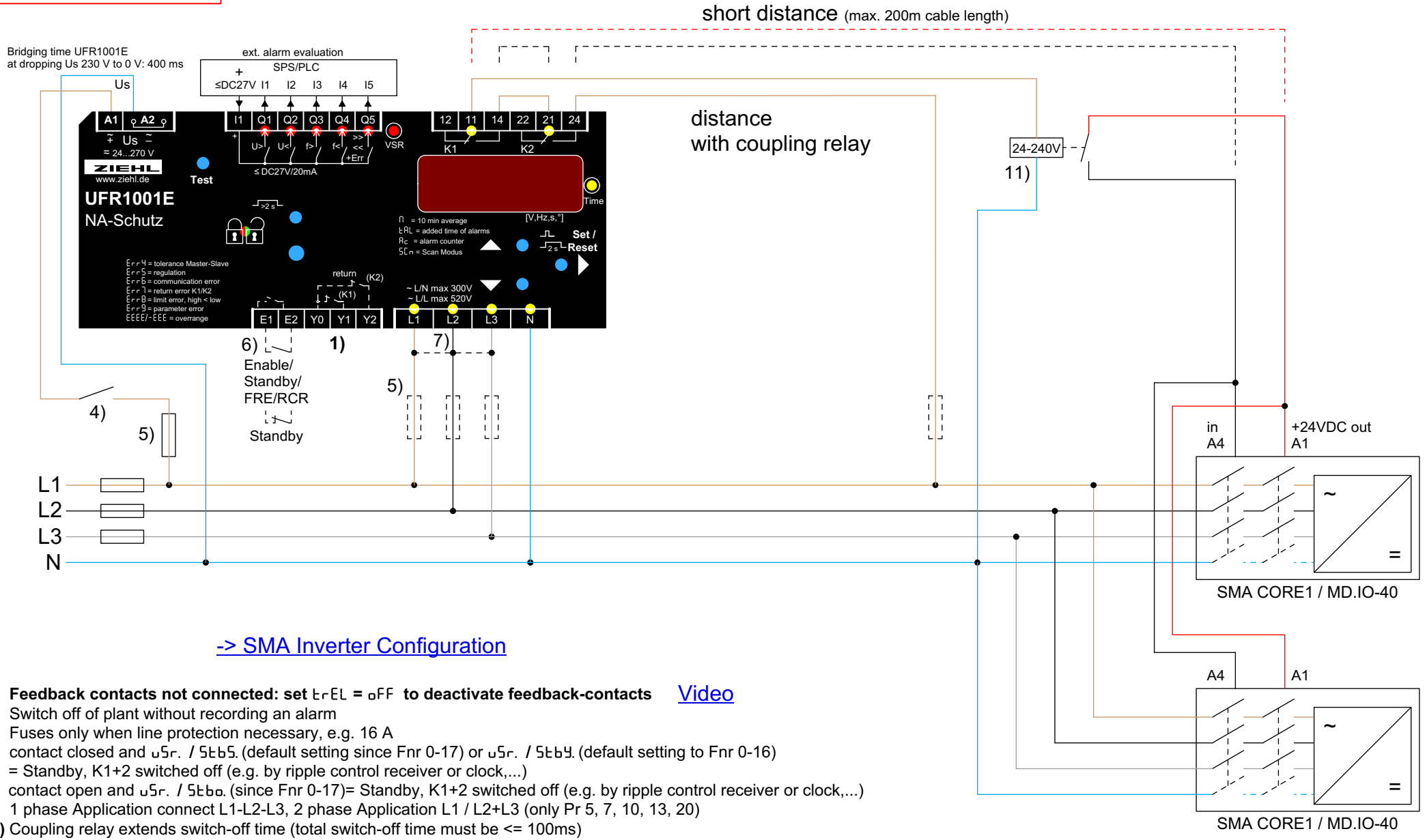

- 1) **Feedback contacts not connected: set ErrEL = OFF to deactivate feedback-contacts** [Video](#)
- 4) Switch off of plant without recording an alarm
- 5) Fuses only when line protection necessary, e.g. 16 A
- 6) contact closed and $u_{5r} / 5t_{b5}$. (default setting since Fnr 0-17) or $u_{5r} / 5t_{b9}$. (default setting to Fnr 0-16)
= Standby, K1+2 switched off (e.g. by ripple control receiver or clock,...)
contact open and $u_{5r} / 5t_{b0}$. (since Fnr 0-17)= Standby, K1+2 switched off (e.g. by ripple control receiver or clock,...)
- 7) 1 phase Application connect L1-L2-L3, 2 phase Application L1 / L2+L3 (only Pr 5, 7, 10, 13, 20)
- 11) Coupling relay extends switch-off time (total switch-off time must be $\leq 100ms$)

VDE-AR-N 4105:2018-11
NA/EEA-NE7 – CH 2020

Bridging time UFR1001E
at dropping Us 230 V to 0 V: 400 ms

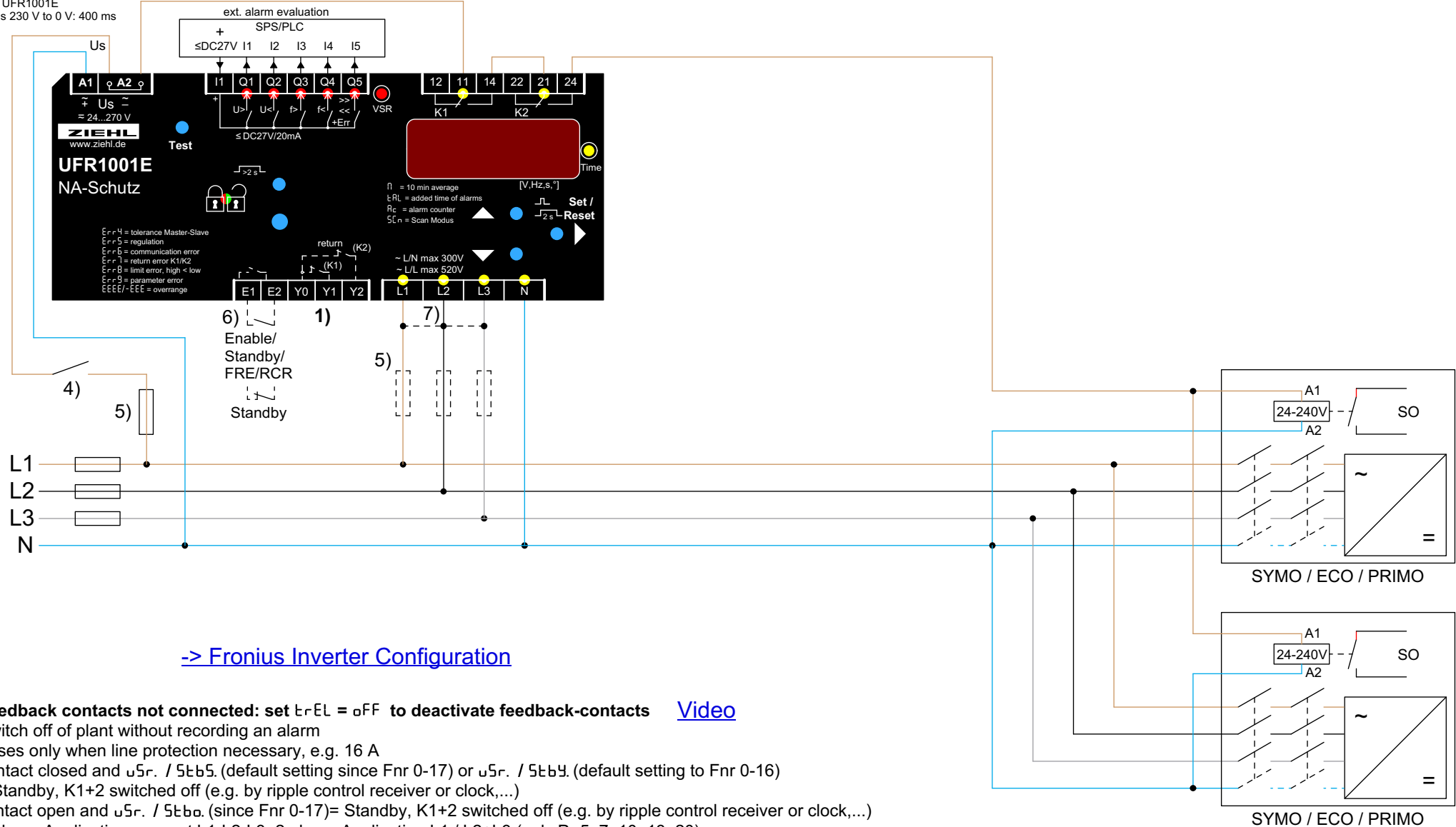

- 1) **Feedback contacts not connected: set $t_{rEL} = OFF$ to deactivate feedback-contacts** [Video](#)
- 4) Switch off of plant without recording an alarm
- 5) Fuses only when line protection necessary, e.g. 16 A
- 6) contact closed and $u_{Sr} / 5t_{b5}$. (default setting since Fnr 0-17) or $u_{Sr} / 5t_{b4}$. (default setting to Fnr 0-16)
= Standby, K1+2 switched off (e.g. by ripple control receiver or clock,...)
- 6) contact open and $u_{Sr} / 5t_{b0}$. (since Fnr 0-17)= Standby, K1+2 switched off (e.g. by ripple control receiver or clock,...)
- 7) 1 phase Application connect L1-L2-L3, 2 phase Application L1 / L2+L3 (only Pr 5, 7, 10, 13, 20)



VDE-AR-N 4105:2018-11

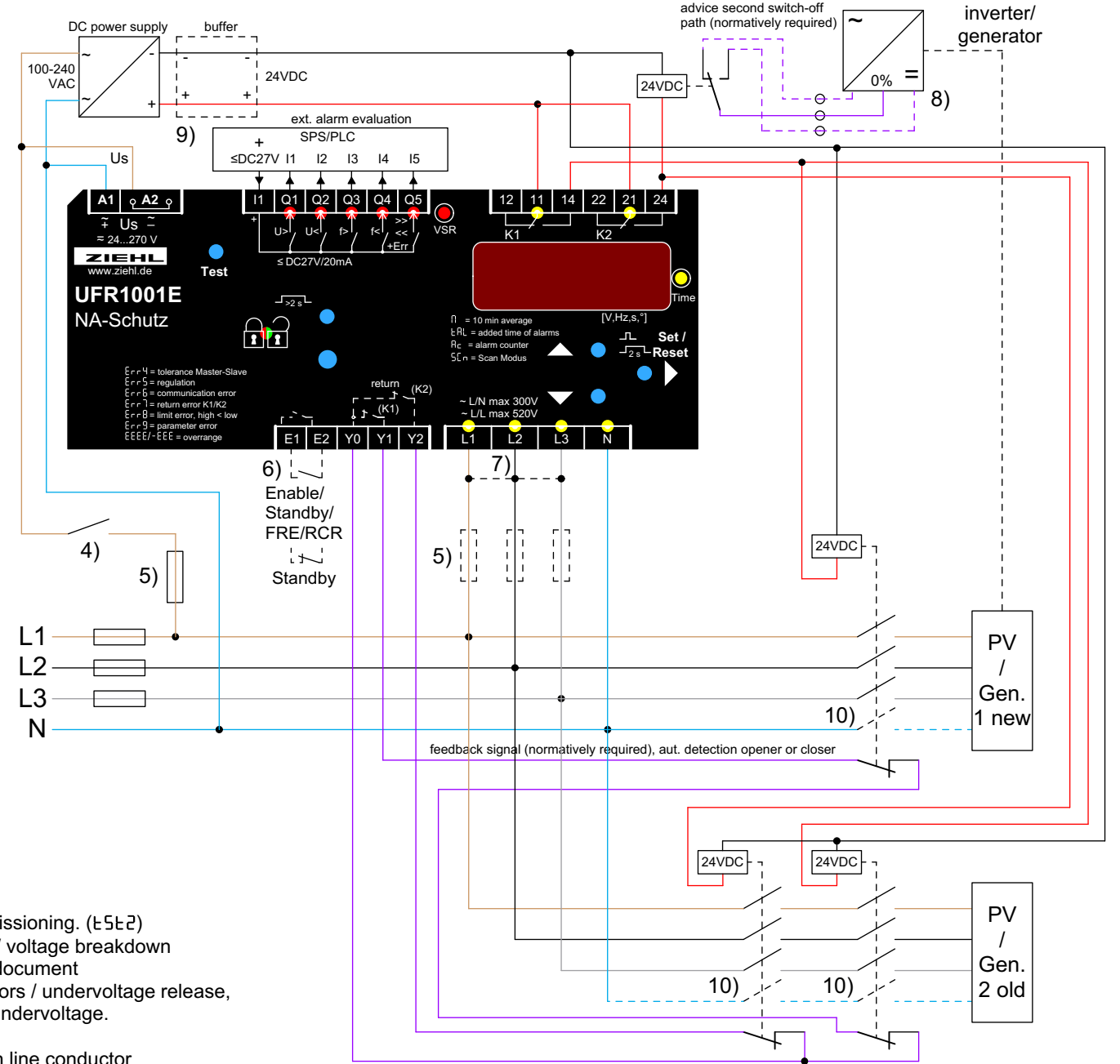

- 4) Switch off of plant without recording an alarm
- 5) Fuses only when line protection necessary, e.g. 16 A
- 6) contact closed and U_{Sr} / $5\epsilon b5$. (default setting since Fnr 0-17) or U_{Sr} / $5\epsilon b5$. (default setting to Fnr 0-16)
= Standby, K1+2 switched off
contact open and U_{Sr} / $5\epsilon b5$. (since Fnr 0-17)
= Standby, K1+2 switched off
(e.g. by ripple control receiver or clock,...)
- 7) 1 phase Application connect L1-L2-L3,
2 phase Application L1 / L2+L3 (only Pr 5, 7, 10, 13, 20)
- 8) Single-fault safety: shutdown of the self generation plant
e.g. by ripple control input 0% with K2. Use
coupling relays ford contact multiplication
of if safe isolation is required.
(control voltage 24-230VAC or feeded over power supply / buffer)
This second switch-off path must be tested separately during commissioning. ($\epsilon 5\epsilon 2$)
- 9) Power supply / buffering. Switches have to withstand undervoltage / voltage breakdown
for min. 3 s / 0,3 s (FRT) The power supplies listed in the separate document
"FRT Komponenteneempfehlung", in connection with 24VDC contactors / undervoltage release,
ensure that the switch-off delay time (3s) is fulfilled in the event of undervoltage.
Bridging time UFR1001E at dropping U_{Sr} 230 V to 0 V: 400 ms
- 10) TT-system: switch all line conductors and N, TN-system: only switch line conductor

VDE-AR-N 4105:2011

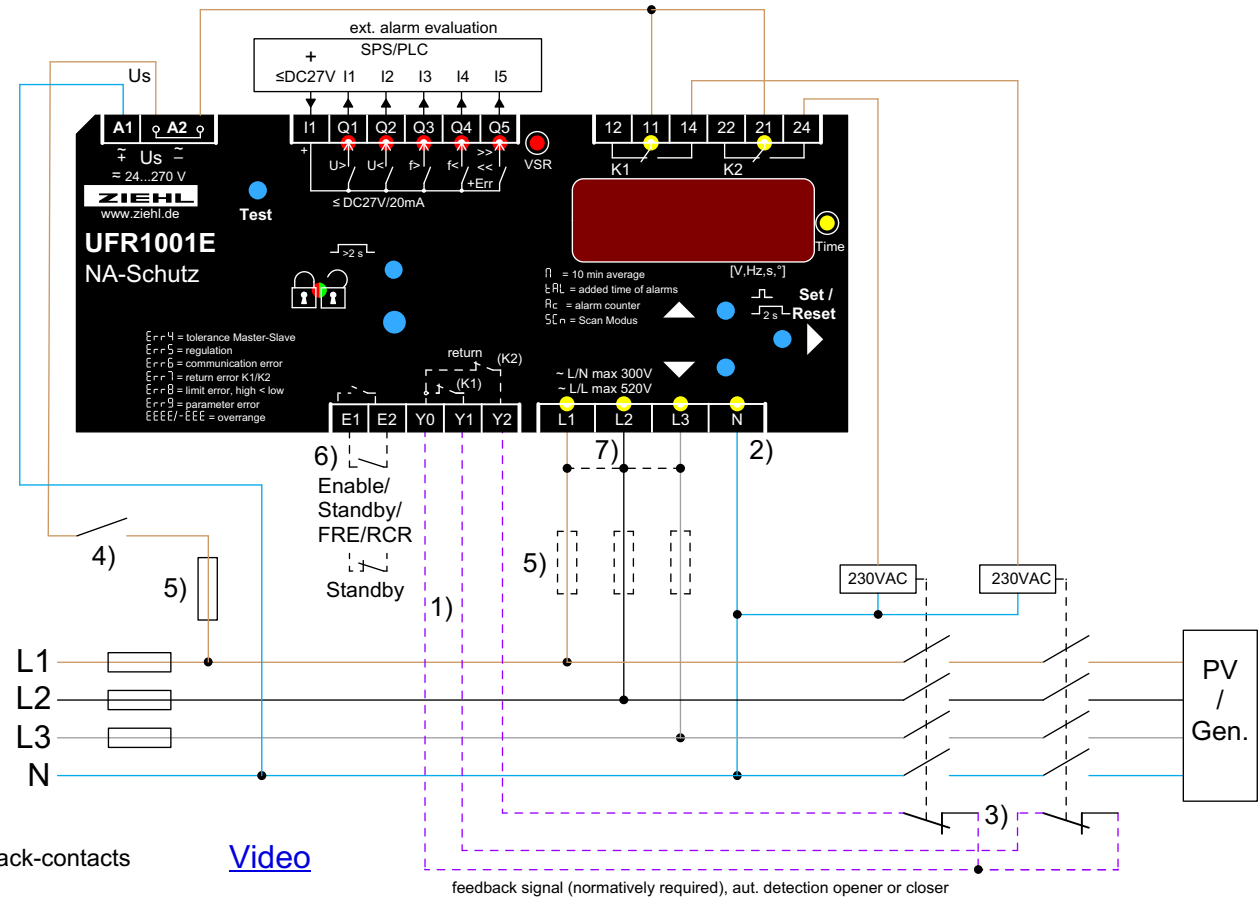

- 1) Feedback contacts not connected: set $t_{rEL} = OFF$ to deactivate feedback-contacts [Video](#)
- 2) N connected → only for programs with N
- 3) NC- or NO-contacts can be connected, self-learning when switching on
- 4) Switch off of plant without recording an alarm
- 5) Fuses only when line protection necessary, e.g. 16 A
- 6) contact closed and $U_{sr} / 5t_{b5}$. (default setting since Fnr 0-17) or $U_{sr} / 5t_{b9}$. (default setting to Fnr 0-16) = Standby, K1+2 switched off (e.g. by ripple control receiver or clock,...)
contact open and $U_{sr} / 5t_{b0}$. (since Fnr 0-17)= Standby, K1+2 switched off (e.g. by ripple control receiver or clock,...)
- 7) 1 phase Application connect L1-L2-L3, 2 phase Application L1 / L2+L3 (only Pr 5, 7, 10, 13, 20)

VDE-AR-N 4105:2018-11

Correct wiring of the 2 section switch:
With correct wiring monitoring of feedback contacts **MUST NOT RESPOND**, when one of the switches is switched off manually.

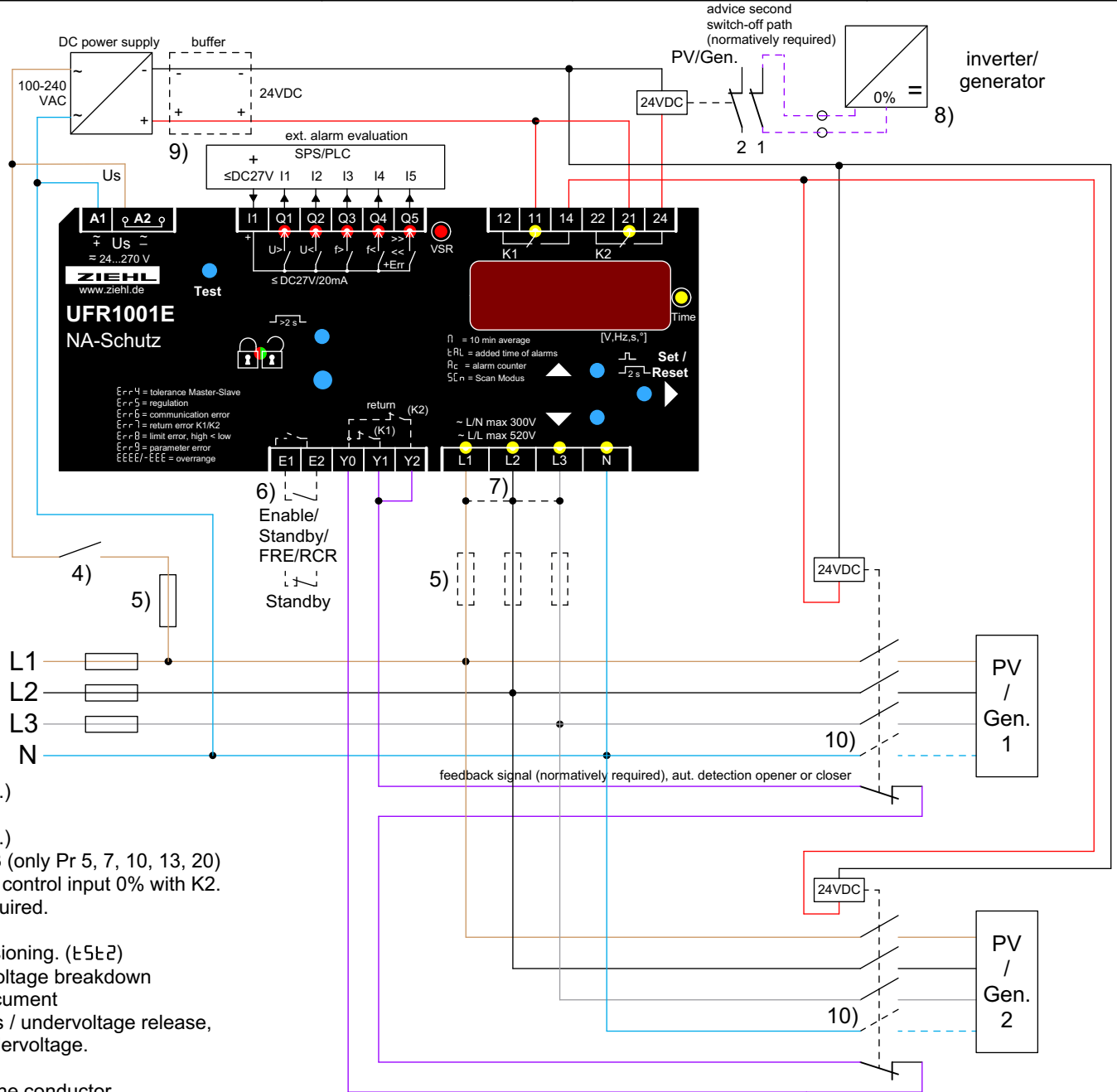

- 4) Switch off of plant without recording an alarm
- 5) Fuses only when line protection necessary, e.g. 16 A
- 6) contact closed and $U_{s-} / 5 \leq U \leq 5$. (default setting since Fnr 0-17) or $U_{s-} / 5 \leq U \leq 5$. (default setting to Fnr 0-16) = Standby, K1+2 switched off (e.g. by ripple control receiver or clock,...) contact open and $U_{s-} / 5 \leq U \leq 5$. (since Fnr 0-17) = Standby, K1+2 switched off (e.g. by ripple control receiver or clock,...)
- 7) 1 phase Application connect L1-L2-L3, 2 phase Application L1 / L2+L3 (only Pr 5, 7, 10, 13, 20)
- 8) Single-fault safety: shutdown of the self generation plant e.g. by ripple control input 0% with K2. Use coupling relays ford contact multiplication of if safe isolation is required. (control voltage 24-230VAC or feeded over power supply / buffer) This second switch-off path must be tested separately during commissioning. (t_{5t2})
- 9) Power supply / buffering. Switches have to withstand undervoltage / voltage breakdown for min. 3 s / 0,3 s (FRT) The power supplies listed in the separate document "FRT Komponentenempfehlung", in connection with 24VDC contactors / undervoltage release, ensure that the switch-off delay time (3s) is fulfilled in the event of undervoltage. Bridging time UFR1001E at dropping U_s 230 V to 0 V: 400 ms
- 10) TT-system: switch all line conductors and N, TN-system: only switch line conductor

VDE-AR-N 4105:2018-11

Correct wiring of the 2x2 section switch:
With correct wiring monitoring of feedback contacts **MUST NOT RESPOND**, when one of the switches is switched off manually.

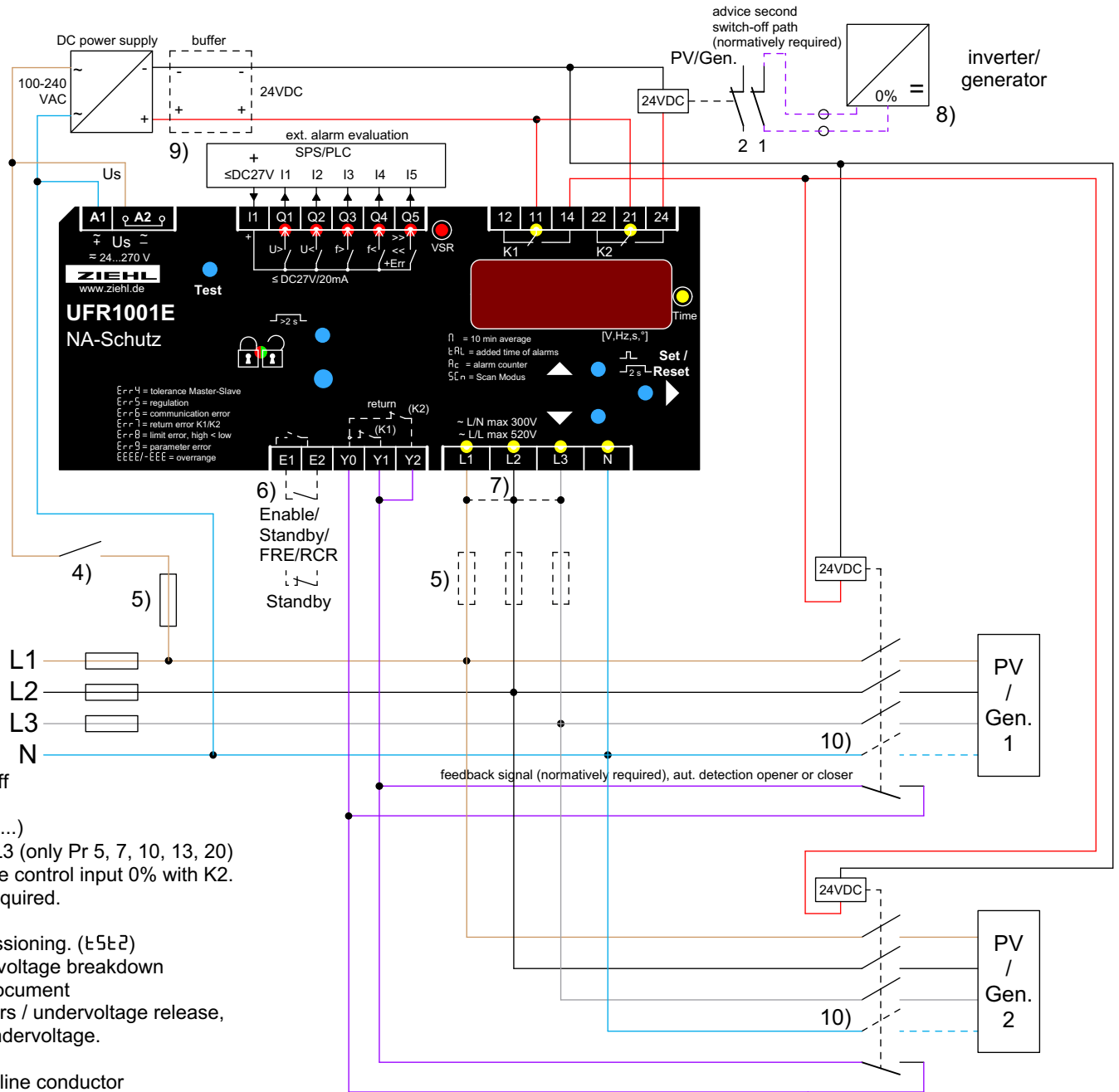

- 4) Switch off of plant without recording an alarm
- 5) Fuses only when line protection necessary, e.g. 16 A
- 6) contact closed and $U_{5r} / 5t_{b5}$. (default setting since Fnr 0-17) or $U_{5r} / 5t_{b4}$. (default setting to Fnr 0-16) = Standby, K1+2 switched off contact open and $U_{5r} / 5t_{b0}$. (since Fnr 0-17) = Standby, K1+2 switched off (e.g. by ripple control receiver or clock,...)
- 7) 1 phase Application connect L1-L2-L3, 2 phase Application L1 / L2+L3 (only Pr 5, 7, 10, 13, 20)
- 8) **Single-fault safety:** shutdown of the self generation plant e.g. by ripple control input 0% with K2. Use coupling relays for contact multiplication of if safe isolation is required. (control voltage 24-230VAC or feeded over power supply / buffer) This second switch-off path must be tested separately during commissioning. (t_{5t2})
- 9) Power supply / buffering. Switches have to withstand undervoltage / voltage breakdown for min. 3 s / 0,3 s (FRT) The power supplies listed in the separate document "FRT Komponenteneempfehlung", in connection with 24VDC contactors / undervoltage release, ensure that the switch-off delay time (3s) is fulfilled in the event of undervoltage. Bridging time UFR1001E at dropping U_s 230 V to 0 V: 400 ms
- 10) TT-system: switch all line conductors and N, TN-system: only switch line conductor

VDE-AR-N 4105:2011
VDE-AR-N 4105:2018-11 Pgen ≤ 50kW

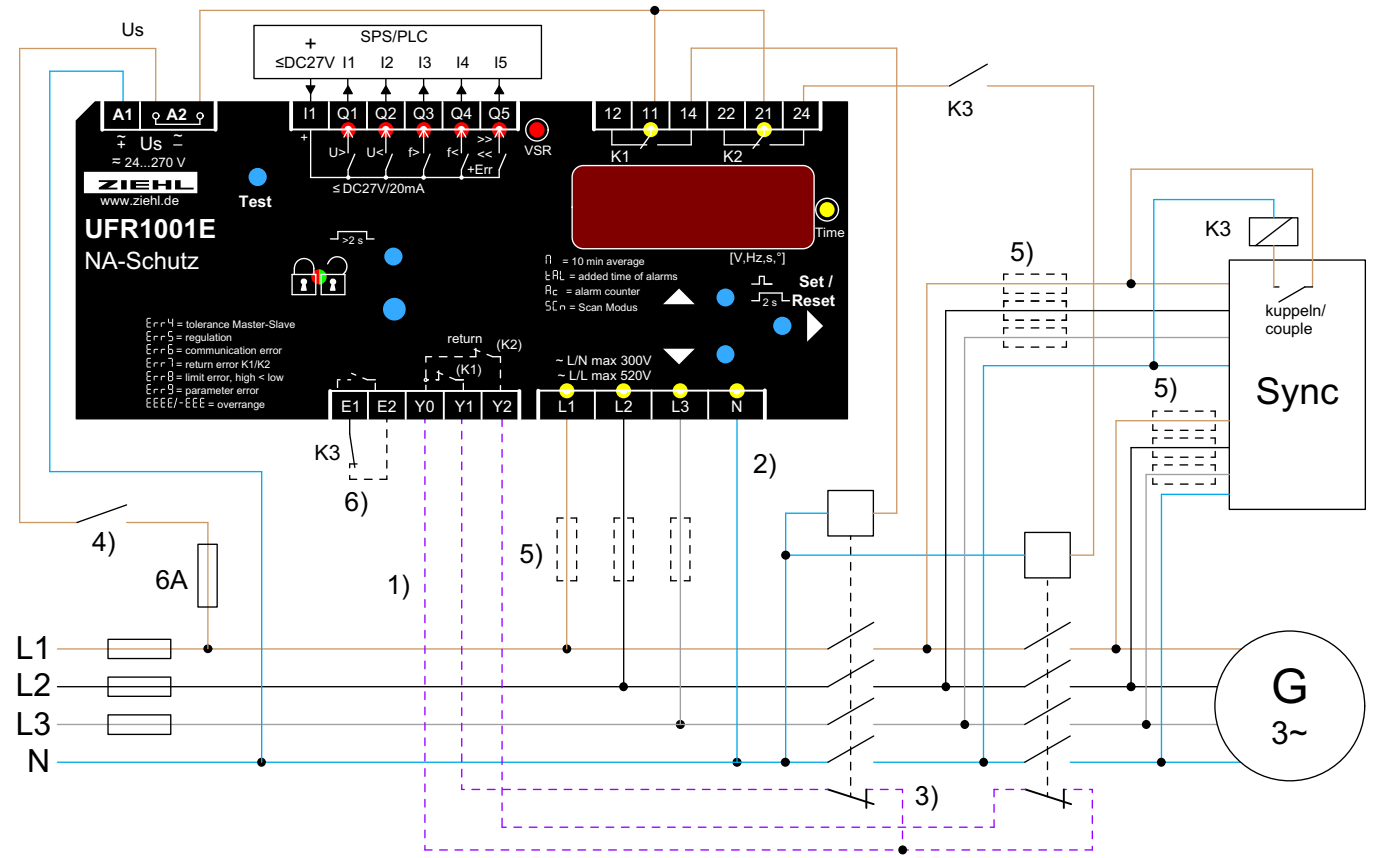

- 1) Feedback contacts not connected: set $t_{r-EL} = OFF$ to deactivate feedback-contacts
- 2) N connected → only for programs with N
- 3) NC- or NO-contacts can be connected, self-learning when switching on
- 4) Switch off of plant without recording an alarm
- 5) Fuses only when line protection necessary, e.g. 16 A
- 6) contact closed and U_{S-} / U_{I2} . (adjust) = no evaluation Y1 and Y2 in switch-on direction

[Video](#)

VDE-AR-N 4105:2018-11

Bridging time UFR1001E
at dropping Us 230 V to 0 V: 400 ms

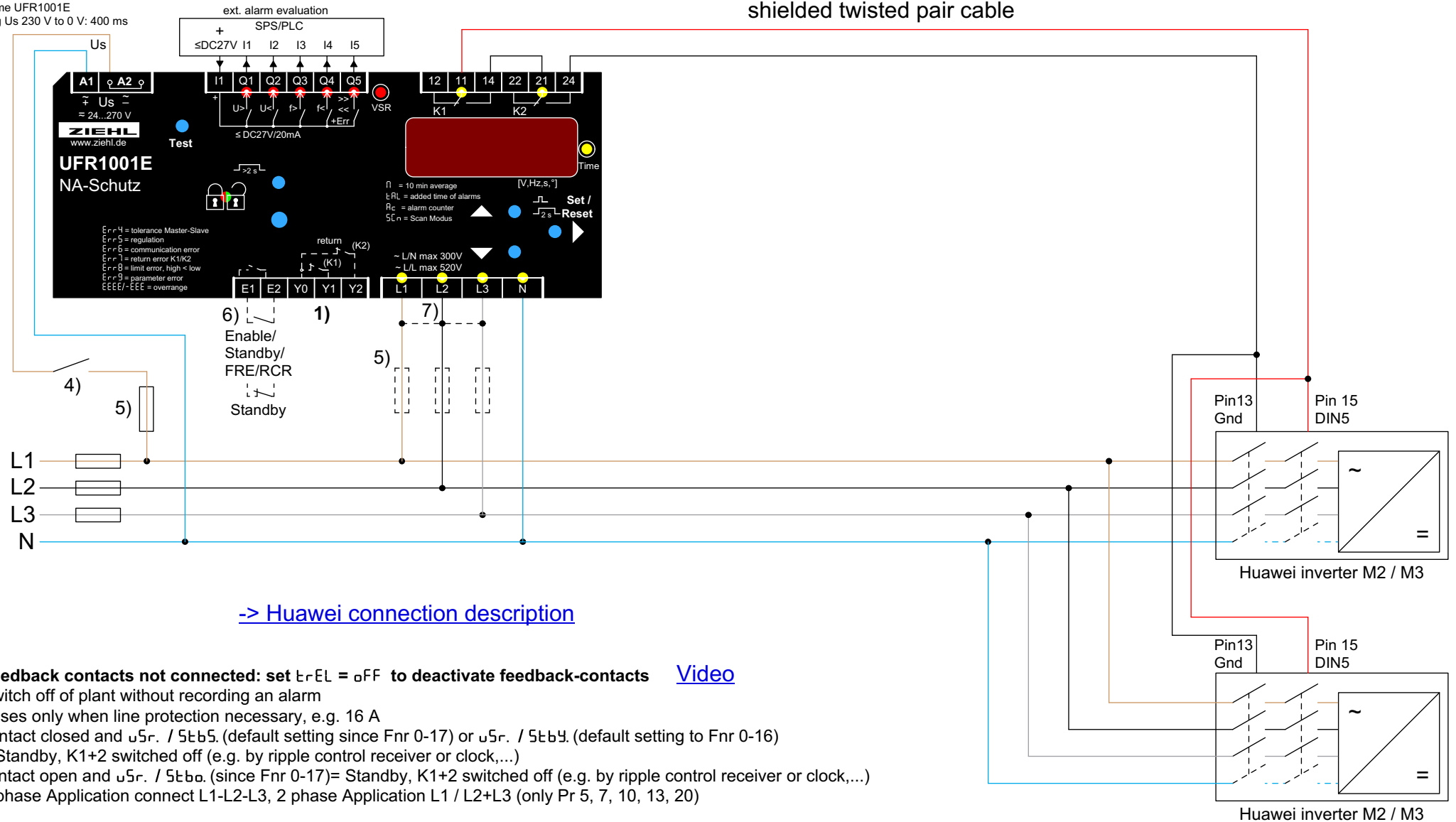

- 1) **Feedback contacts not connected: set ErrEL = OFF to deactivate feedback-contacts** [Video](#)
- 4) Switch off of plant without recording an alarm
- 5) Fuses only when line protection necessary, e.g. 16 A
- 6) contact closed and $U_{Sr} / 5 \leq U_{S}$. (default setting since Fnr 0-17) or $U_{Sr} / 5 \leq U_{S}$. (default setting to Fnr 0-16)
= Standby, K1+2 switched off (e.g. by ripple control receiver or clock,...)
contact open and $U_{Sr} / 5 \leq U_{S}$. (since Fnr 0-17)= Standby, K1+2 switched off (e.g. by ripple control receiver or clock,...)
- 7) 1 phase Application connect L1-L2-L3, 2 phase Application L1 / L2+L3 (only Pr 5, 7, 10, 13, 20)

VDE-AR-N 4110:2018-11 (medium voltage)

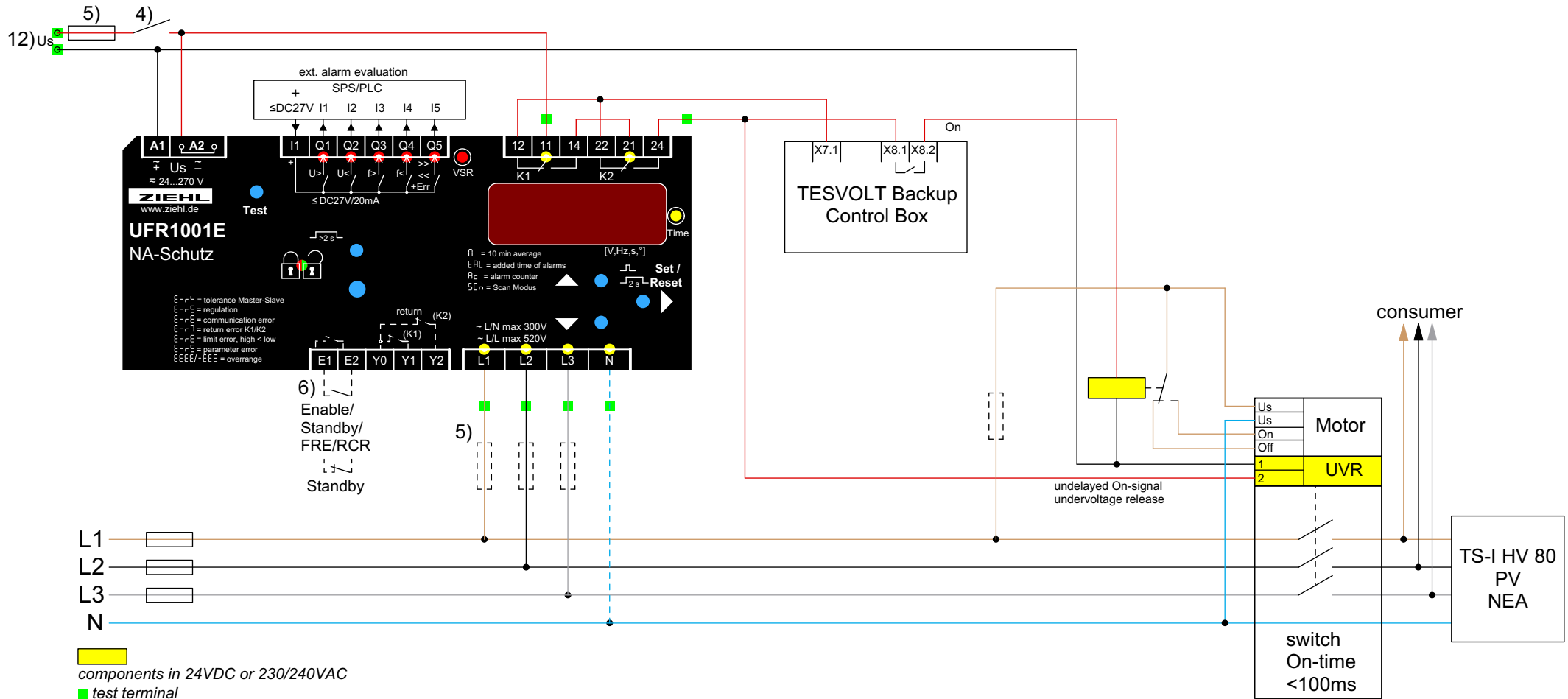

- 4) Switch off of plant without recording an alarm
- 5) Fuses only when line protection necessary, e.g. 16 A
- 6) contact closed and u_{5r} / $5\epsilon b5$. (default setting is Fnr 0-17) or u_{5r} / $5\epsilon b9$. (default setting to Fnr 0-16) = Standby, K1+2 switched off (e.g. by ripple control receiver or clock,...) contact open and u_{5r} / $5\epsilon b6$. (since Fnr 0-17)= Standby, K1+2 switched off (e.g. by ripple control receiver or clock,...)
- 12) (existing) control voltage that ensures the protective functions for at min. 5s, e.g. by using a DC power supply unit with wide-range input and buffering

**VDE-AR-N 4105:2018-11
NA/EEA-NE7 – CH 2020**

DC power supply must be designed for 2 contactors (switch-on power) use buffer module if necessary

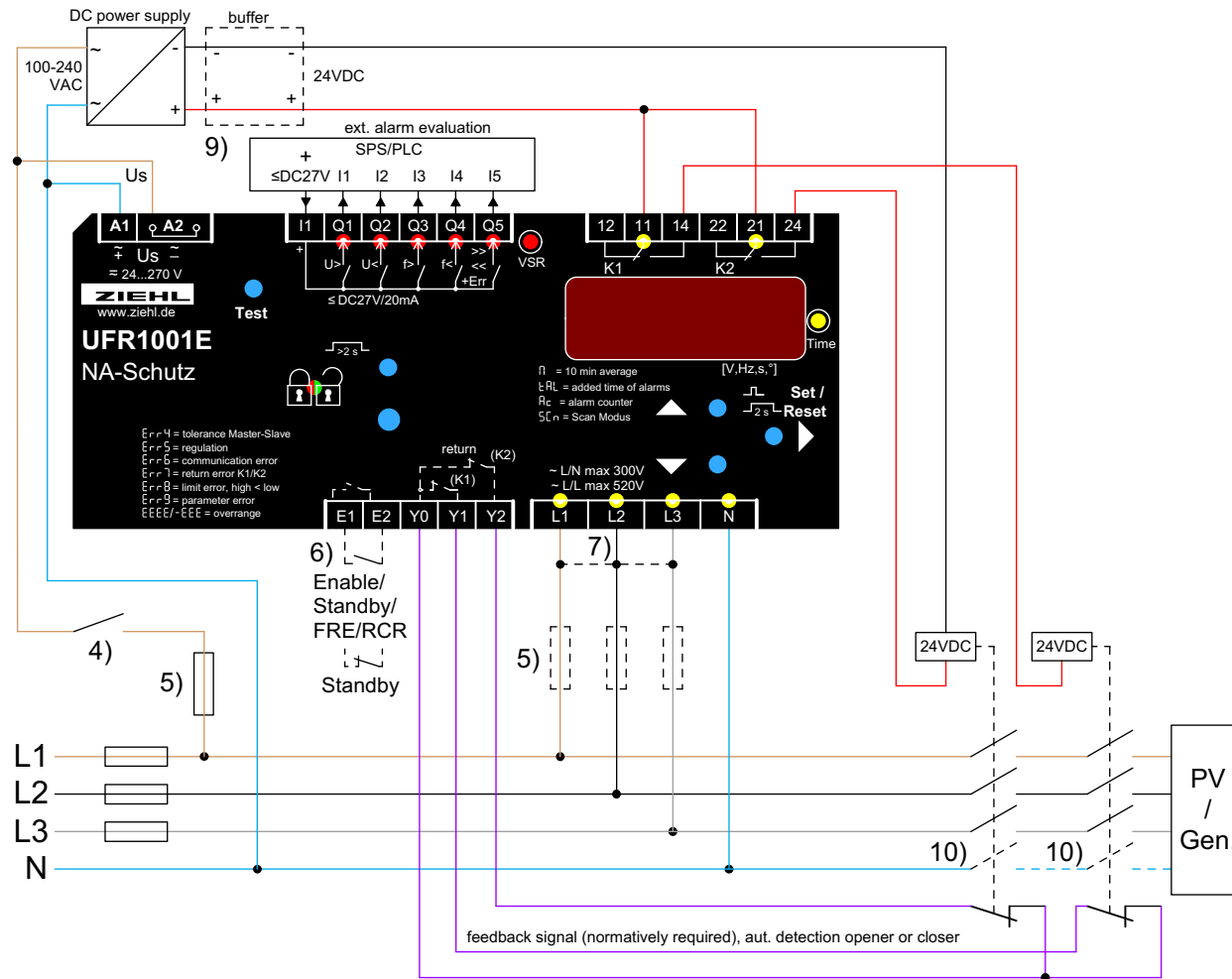

- 4) Switch off of plant without recording an alarm
- 5) Fuses only when line protection necessary, e.g. 16 A
- 6) contact closed and U_{5r} / 5t₅. (default setting since Fnr 0-17) or U_{5r} / 5t₅. (default setting to Fnr 0-16) = Standby, K1+2 switched off (e.g. by ripple control receiver or clock,...)
contact open and U_{5r} / 5t₅. (since Fnr 0-17)= Standby, K1+2 switched off (e.g. by ripple control receiver or clock,...)
- 7) 1 phase Application connect L1-L2-L3, 2 phase Application L1 / L2+L3 (only Pr 5, 7, 10, 13, 20)
- 9) Power supply / buffering. Switches have to withstand undervoltage / voltage breakdown for min. 3 s / 0,3 s (FRT)
The power supplies listed in the separate document "FRT Komponentenempfehlung", in connection with 24VDC contactors / undervoltage release, ensure that the switch-off delay time (3s) is fulfilled in the event of undervoltage. Bridging time UFR1001E at dropping U_s 230 V to 0 V: 400 ms
- 10) TT-system: switch all line conductors and N, TN-system: only switch line conductor

VDE-AR-N 4105:2018-11

Bridging time UFR1001E
at dropping Us 230 V to 0 V: 400 ms

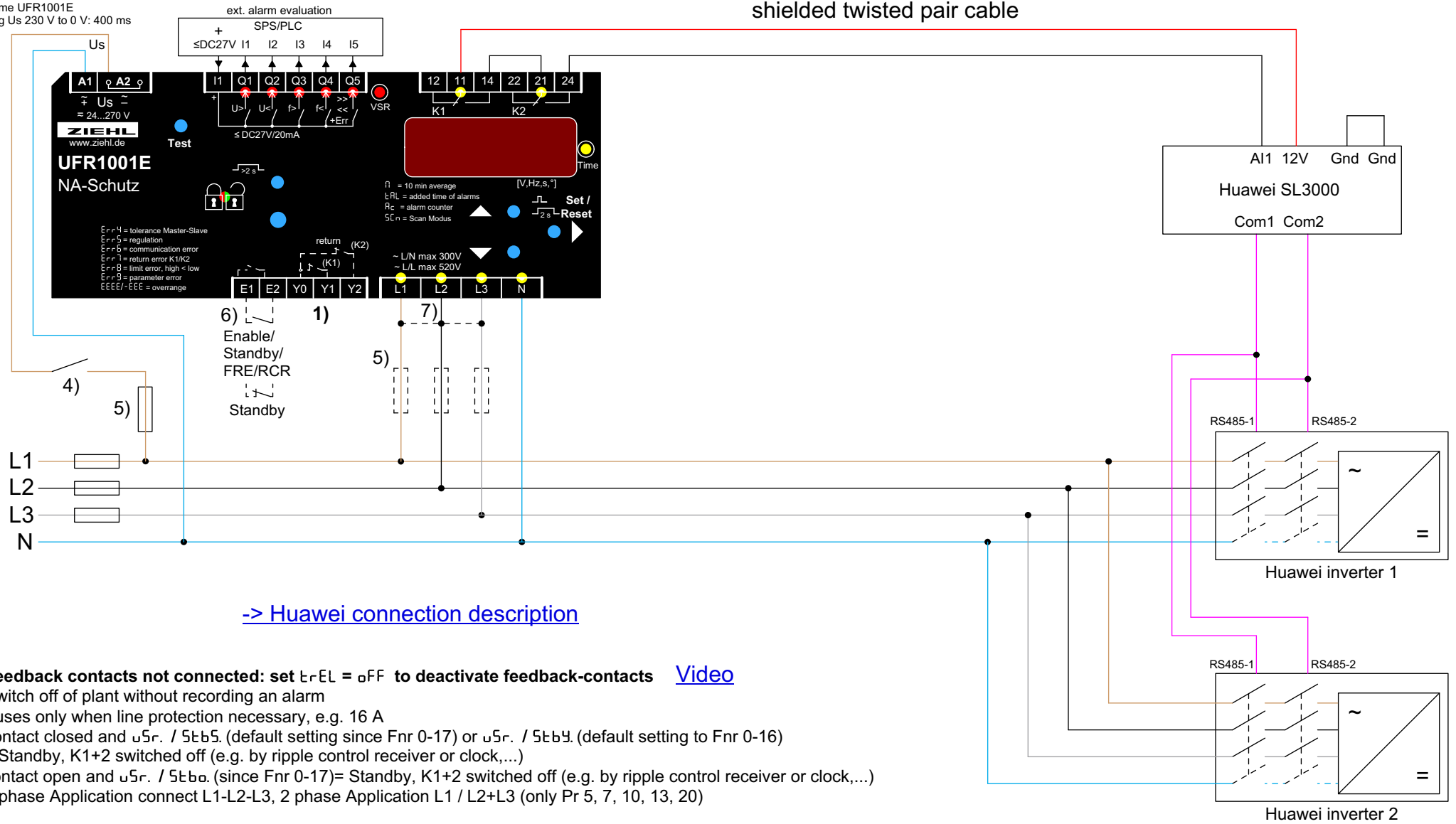

[-> Huawei connection description](#)

- 1) **Feedback contacts not connected: set $t_{rEL} = \text{OFF}$ to deactivate feedback-contacts** [Video](#)
- 4) Switch off of plant without recording an alarm
- 5) Fuses only when line protection necessary, e.g. 16 A
- 6) contact closed and $u_{Sr} / 5t_{b5}$. (default setting since Fnr 0-17) or $u_{Sr} / 5t_{b4}$. (default setting to Fnr 0-16)
= Standby, K1+2 switched off (e.g. by ripple control receiver or clock,...)
- contact open and $u_{Sr} / 5t_{b0}$. (since Fnr 0-17)= Standby, K1+2 switched off (e.g. by ripple control receiver or clock,...)
- 7) 1 phase Application connect L1-L2-L3, 2 phase Application L1 / L2+L3 (only Pr 5, 7, 10, 13, 20)



VDE-AR-N 4105:2018-11

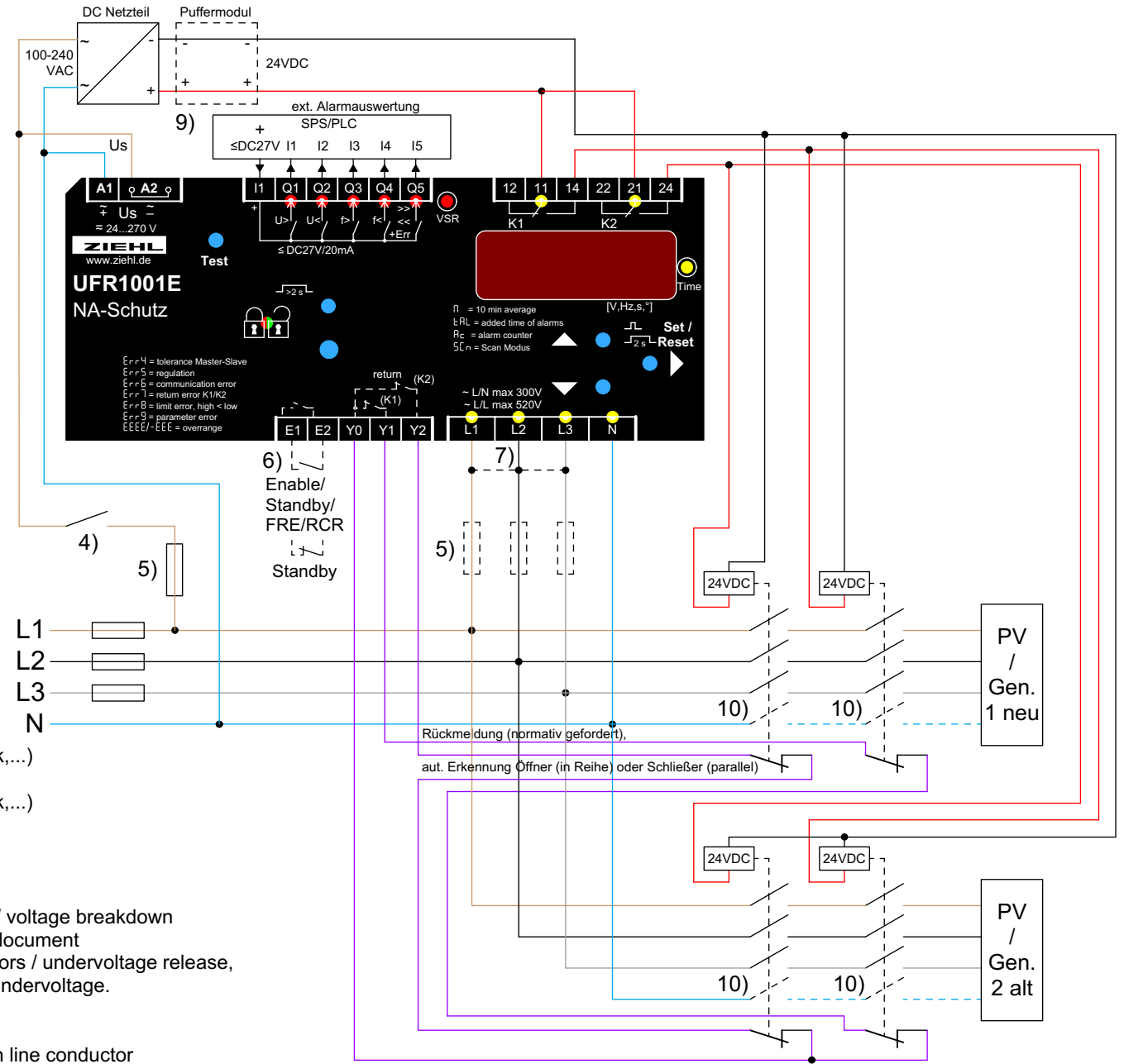

- 4) Switch off of plant without recording an alarm
- 5) Fuses only when line protection necessary, e.g. 16 A
- 6) contact closed and $u_{Sr} / 5t_{b5}$. (default setting since Fnr 0-17) or $u_{Sr} / 5t_{b4}$. (default setting to Fnr 0-16)
= Standby, K1+2 switched off (e.g. by ripple control receiver or clock,...)
contact open and $u_{Sr} / 5t_{b0}$. (since Fnr 0-17)
= Standby, K1+2 switched off (e.g. by ripple control receiver or clock,...)
- 7) 1 phase Application connect L1-L2-L3,
2 phase Application L1 / L2+L3 (only Pr 5, 7, 10, 13, 20)
- 9) Power supply / buffering. Switches have to withstand undervoltage / voltage breakdown for min. 3 s / 0,3 s (FRT) The power supplies listed in the separate document "FRT Komponenteneempfehlung", in connection with 24VDC contactors / undervoltage release, ensure that the switch-off delay time (3s) is fulfilled in the event of undervoltage. Bridging time UFR1001E at dropping U_s 230 V to 0 V: 400 ms
- 10) TT-system: switch all line conductors and N, TN-system: only switch line conductor

VDE-AR-N 4105:2018-11
NA/EEA-NE7 – CH 2020

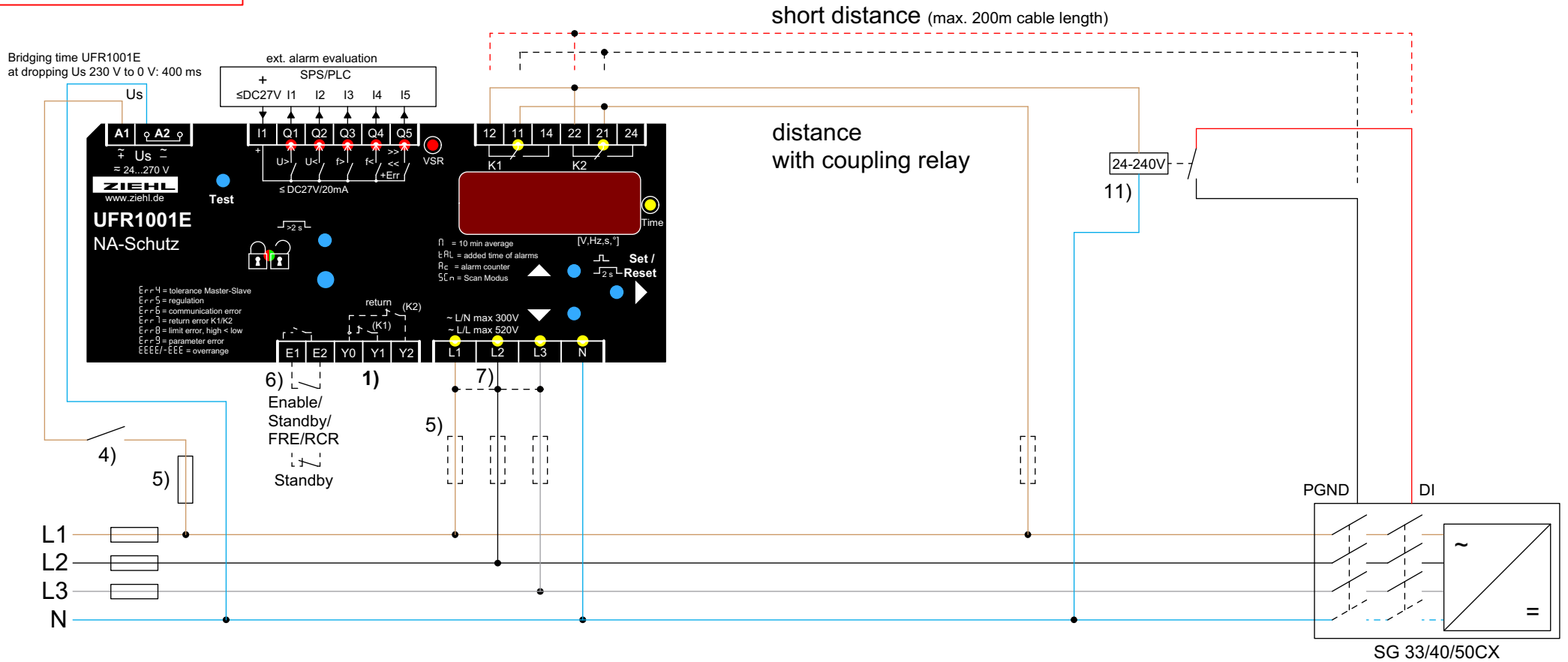

-> Sungrow Inverter Configuration

- 1) **Feedback contacts not connected: set $E_{rEL} = OFF$ to deactivate feedback-contacts** [Video](#)
- 4) Switch off of plant without recording an alarm
- 5) Fuses only when line protection necessary, e.g. 16 A
- 6) contact closed and $U_{5r} / 5t_{b5}$. (default setting since Fnr 0-17) or $U_{5r} / 5t_{b9}$. (default setting to Fnr 0-16)
= Standby, K1+2 switched off (e.g. by ripple control receiver or clock,...)
contact open and $U_{5r} / 5t_{b0}$. (since Fnr 0-17)= Standby, K1+2 switched off (e.g. by ripple control receiver or clock,...)
- 7) 1 phase Application connect L1-L2-L3, 2 phase Application L1 / L2+L3 (only Pr 5, 7, 10, 13, 20)
- 11) Coupling relay extends switch-off time (total switch-off time must be $\leq 100ms$)

Notice:
The inverter switches off,
when a contact at input DI is closed.
In the event of a cable break or line interruption,
the switch-off no longer works.